



HC 110

110 USt capacity
Hydraulic crawler crane
Datasheet
imperial

HC 110



WORKS FOR YOU.™

	Page:
Key	3
Highlights	3
Dimensions	4
Range Diagram 59HI Chord Boom	6
Load Charts With 59HI Offset Tip Boom – 4 Sheave Tip	7
Range Diagram 59HI Boom, #9HL Jib	11
Load Charts With 59HI Offset Tip Boom – 4 Sheave Tip, #9HL Jib	12
Technical Description Hydraulic Crawler Crane	18
Transport Example for HC 110	19

Features:

- ▶ 110 tons (100 mt) maximum lifting capacity
- ▶ 230 ft (70 m) maximum length of main boom
- ▶ 200 ft + 70 ft (61 m + 21 m) maximum boom and jib
- ▶ Power up / down and freefall on main and auxiliary drums
- ▶ Quiet, comfortable operator's cab with excellent viewing range
- ▶ Hydraulic counterweight removal system simplifies installation and removal
- ▶ Superior transportability – 11 ft (3.35 m) width; 11 ft 3 inch (3.43 m) height
- ▶ 105,000 lb (47 627 kg) transport weight includes sideframes, 3rd drum and boom inner



KEY



Counterweight

SC

Sideframe Counterweight

DIMENSIONS

HC 110

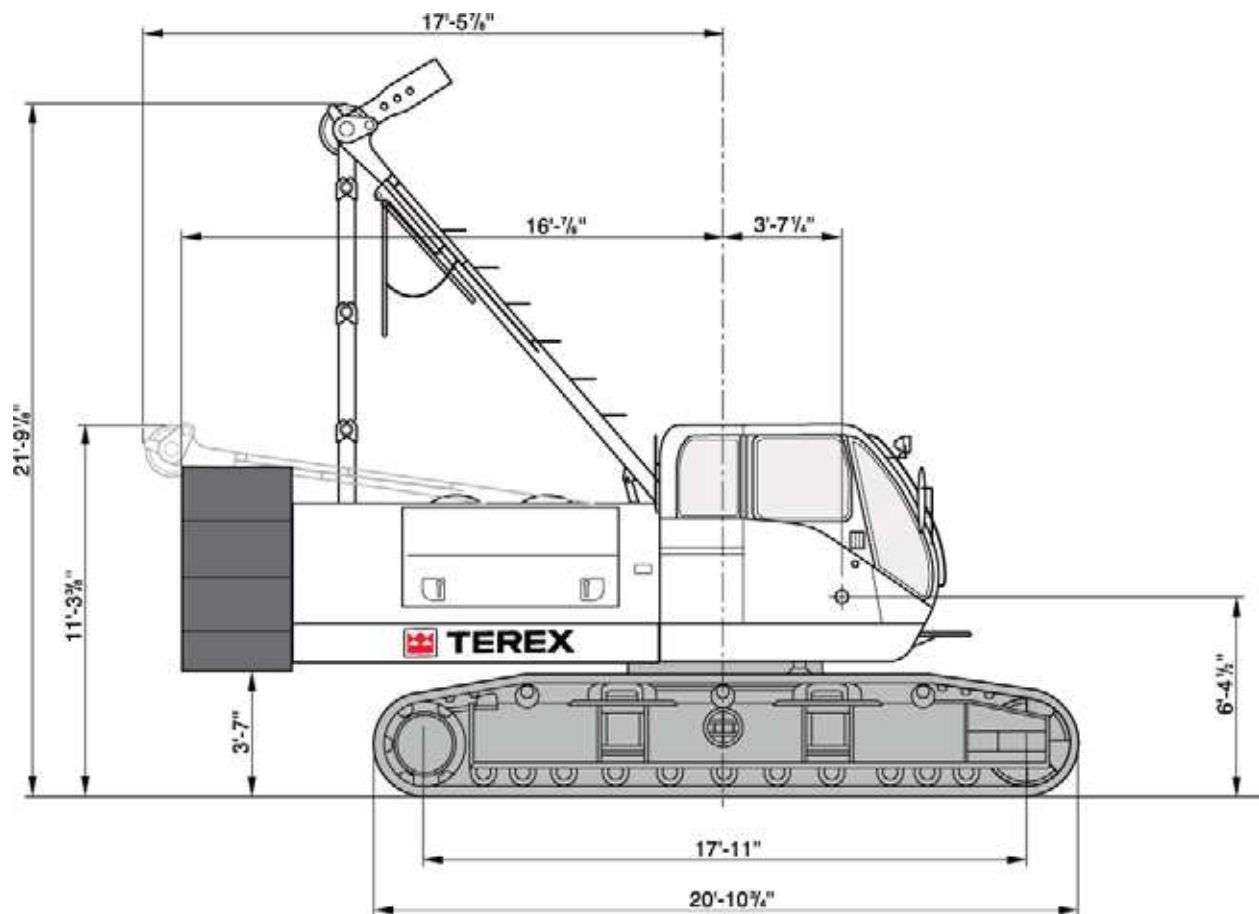

DIMENSIONS

HC 110

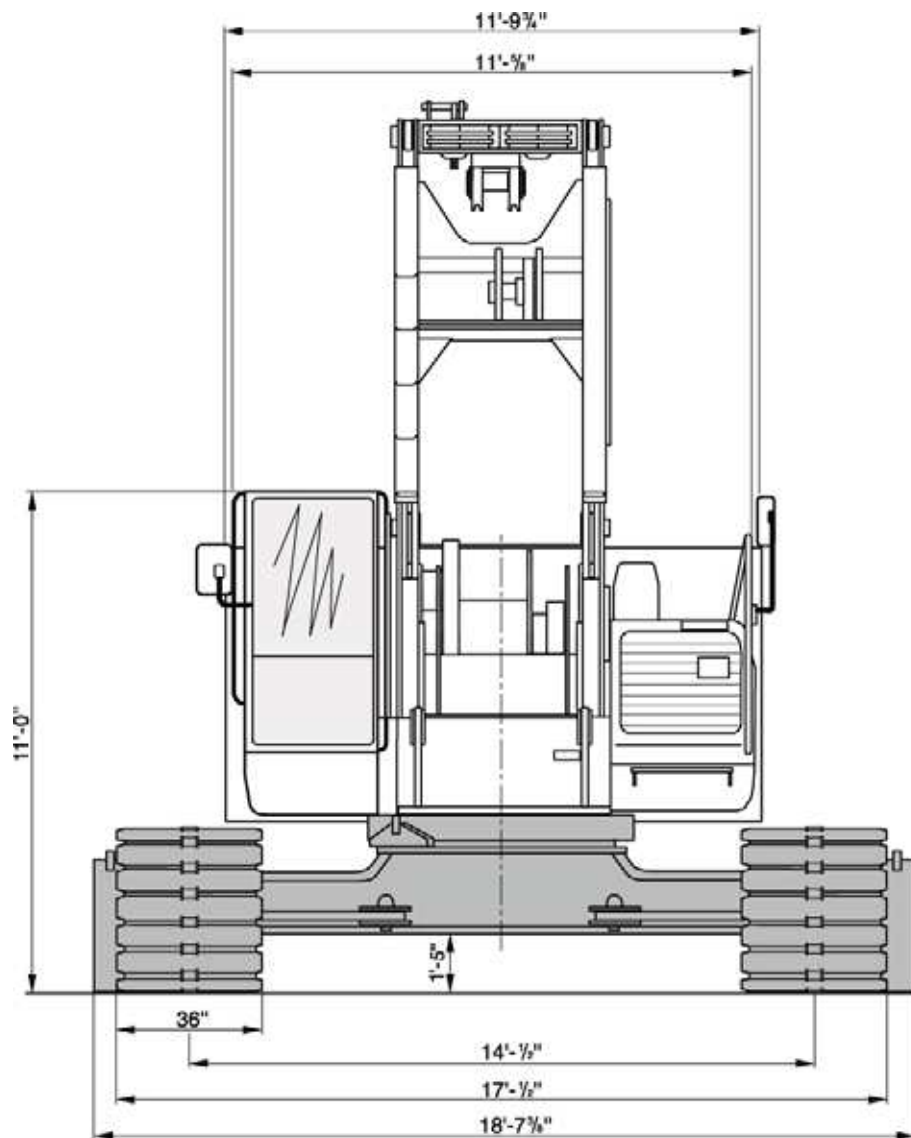

RANGE DIAGRAM

HC 110

59HI Chord Boom

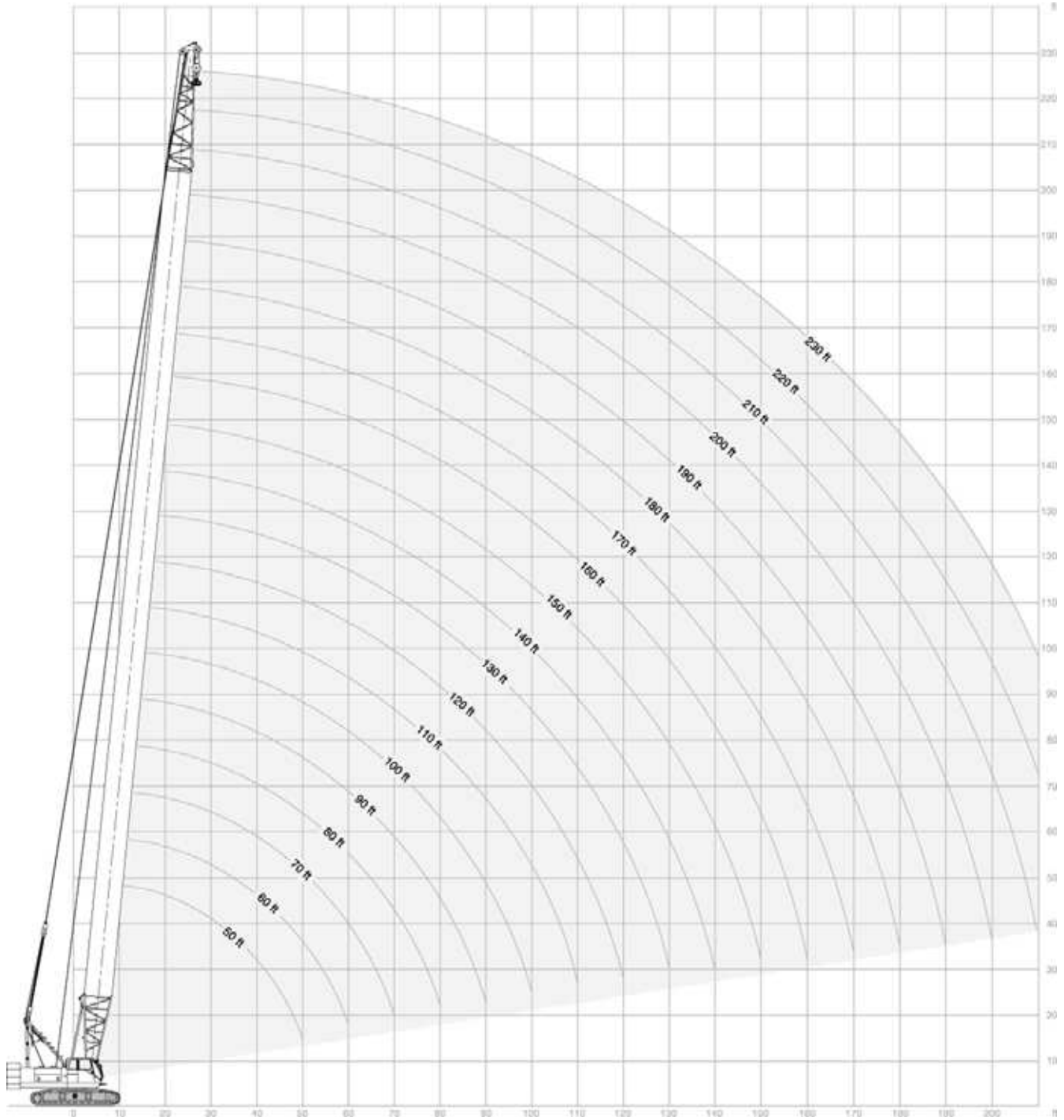

LOAD CHART

HC 110

With 59HI Offset Tip Boom – 4 Sheave Tip

52,900 lb + 23,000 lb SC				360°				ANSI B 30.5			
50' (15.2 m) Boom length				90' (27.4 m) Boom length							
Radius (Feet)	Boom Angle (Degrees)	Side Frames Extended (Pounds)	From Boom Pt. to Ground (Feet)	Radius (Feet)	Boom Angle (Degrees)	Side Frames Extended (Pounds)	From Boom Pt. to Ground (Feet)				
13	79.9	220,000 *	56	19	80.6	133,440	95				
15	77.6	190,080 *	55	20	79.9	122,580	95				
20	71.6	123,290	54	25	76.7	86,970	94				
25	65.4	87,670	52	30	73.4	66,860	93				
30	58.9	67,640	49	35	70.0	54,150	91				
35	51.9	54,900	46	40	66.6	45,210	89				
40	44.1	46,010	41	50	59.4	33,630	84				
50	22.7	34,480	26	60	51.6	26,570	77				
				70	42.9	21,670	68				
				80	32.3	18,120	55				
				90	16.7	15,440	32				
60' (18.3 m) Boom length				100' (30.5 m) Boom length							
Radius (Feet)	Boom Angle (Degrees)	Side Frames Extended (Pounds)	From Boom Pt. to Ground (Feet)	Radius (Feet)	Boom Angle (Degrees)	Side Frames Extended (Pounds)	From Boom Pt. to Ground (Feet)				
14	80.7	203,570 *	66	20	80.9	122,380	105				
15	79.7	189,950 *	65	25	78.0	86,760	104				
20	74.8	123,100	64	30	75.1	66,630	103				
25	69.7	87,490	63	35	72.1	53,930	102				
30	64.5	67,430	61	40	69.0	44,980	100				
35	59.1	54,700	58	50	62.7	33,380	95				
40	53.3	45,790	54	60	56.0	26,340	89				
50	40.0	34,250	45	70	48.8	21,430	82				
60	20.6	27,130	27	80	40.6	17,880	71				
				90	30.6	15,190	57				
				100	15.8	13,090	34				
70' (21.3 m) Boom length				110' (33.5 m) Boom length							
Radius (Feet)	Boom Angle (Degrees)	Side Frames Extended (Pounds)	From Boom Pt. to Ground (Feet)	Radius (Feet)	Boom Angle (Degrees)	Side Frames Extended (Pounds)	From Boom Pt. to Ground (Feet)				
16	80.3	177,910 *	75	22	80.7	105,050	115				
20	77.0	122,950	75	25	79.1	86,580	114				
25	72.8	87,320	73	30	76.5	66,410	113				
30	68.4	67,250	71	35	73.8	53,720	112				
35	63.9	54,530	69	40	71.0	44,760	110				
40	59.2	45,620	67	50	65.4	33,160	106				
50	49.0	34,050	59	60	59.5	26,130	101				
60	36.9	26,960	48	70	53.2	21,220	94				
70	19.0	22,070	29	80	46.4	17,650	86				
				90	38.6	14,960	75				
				100	29.1	12,860	60				
				110	15.1	11,180	35				
80' (24.4 m) Boom length											
Radius (Feet)	Boom Angle (Degrees)	Side Frames Extended (Pounds)	From Boom Pt. to Ground (Feet)								
17	80.8	161,850	85								
20	78.7	122,740	85								
25	75.0	87,130	84								
30	71.2	67,020	82								
35	67.4	54,310	80								
40	63.4	45,380	78								
50	55.0	33,810	72								
60	45.7	26,730	64								
70	34.4	21,840	52								
80	17.7	18,300	31								

* see page 10 „Notes to lifting capacity“

LOAD CHART

HC 110

With 59HI Offset Tip Boom – 4 Sheave Tip

52,900 lb + 23,000 lb SC				360°				ANSI B 30.5			
120' (36.6 m) Boom length				150' (45.7 m) Boom length							
Radius (Feet)	Boom Angle (Degrees)	Side Frames Extended (Pounds)	From Boom Pt. to Ground (Feet)	Radius (Feet)	Boom Angle (Degrees)	Side Frames Extended (Pounds)	From Boom Pt. to Ground (Feet)				
24	80.5	91,640	125	28	80.9	72,450	154				
25	80.1	86,370	125	30	80.1	65,530	154				
30	77.6	66,180	124	35	78.2	52,860	153				
35	75.2	53,490	122	40	76.2	43,870	152				
40	72.7	44,530	121	50	72.2	32,220	149				
50	67.6	32,910	117	60	68.2	25,230	146				
60	62.3	25,890	113	70	64.0	20,300	141				
70	56.7	20,970	107	80	59.6	16,730	136				
80	50.8	17,410	99	90	55.1	14,020	129				
90	44.3	14,720	90	100	50.3	11,910	122				
100	36.9	12,600	78	110	45.1	10,210	113				
110	27.9	10,910	62	120	39.4	8,810	102				
120	14.4	9,540	36	130	32.8	7,640	88				
				140	24.9	6,670	69				
				150	12.8	5,840	40				
130' (39.6 m) Boom length				160' (48.8 m) Boom length							
Radius (Feet)	Boom Angle (Degrees)	Side Frames Extended (Pounds)	From Boom Pt. to Ground (Feet)	Radius (Feet)	Boom Angle (Degrees)	Side Frames Extended (Pounds)	From Boom Pt. to Ground (Feet)				
25	80.8	86,180	135	30	80.7	65,300	164				
30	78.6	65,990	134	35	78.9	52,640	163				
35	76.3	53,300	133	40	77.1	43,640	162				
40	74.0	44,340	131	50	73.4	31,960	160				
50	69.4	32,700	128	60	69.6	24,990	156				
60	64.6	25,690	124	70	65.7	20,060	152				
70	59.6	20,770	118	80	61.7	16,480	147				
80	54.3	17,210	112	90	57.6	13,770	141				
90	48.6	14,510	104	100	53.2	11,650	134				
100	42.4	12,400	94	110	48.6	9,950	126				
110	35.4	10,700	82	120	43.6	8,550	117				
120	26.7	9,310	65	130	38.1	7,380	105				
130	13.8	8,160	37	140	31.8	6,400	91				
				150	24.0	5,550	72				
				160	12.4	4,850	41				
140' (42.7 m) Boom length				170' (51.8 m) Boom length							
Radius (Feet)	Boom Angle (Degrees)	Side Frames Extended (Pounds)	From Boom Pt. to Ground (Feet)	Radius (Feet)	Boom Angle (Degrees)	Side Frames Extended (Pounds)	From Boom Pt. to Ground (Feet)				
27	80.7	76,660	145	31	80.9	62,050	174				
30	79.4	65,750	144	35	79.6	52,430	174				
35	77.3	53,070	143	40	77.9	43,420	173				
40	75.2	44,100	142	50	74.4	31,740	170				
50	70.9	32,450	139	60	70.8	24,780	167				
60	66.5	25,450	135	70	67.2	19,850	163				
70	62.0	20,530	130	80	63.5	16,270	159				
80	57.2	16,960	124	90	59.7	13,560	153				
90	52.2	14,260	117	100	55.7	11,430	147				
100	46.8	12,140	108	110	51.5	9,730	139				
110	40.8	10,440	98	120	47.0	8,320	131				
120	34.0	9,050	85	130	42.2	7,150	121				
130	25.7	7,890	67	140	36.9	6,160	108				
140	13.3	6,920	39	150	30.8	5,320	93				
				160	23.3	4,600	74				
				170	12.1	3,990	42				



LOAD CHART

HC 110

With 59HI Offset Tip Boom – 4 Sheave Tip

52,900 lb + 23,000 lb SC				360°				ANSI B 30.5			
180' (54.9 m) Boom length				210' (64.0 m) Boom length							
Radius (Feet)	Boom Angle (Degrees)	Side Frames Extended (Pounds)	From Boom Pt. to Ground (Feet)	Radius (Feet)	Boom Angle (Degrees)	Side Frames Extended (Pounds)	From Boom Pt. to Ground (Feet)	Radius (Feet)	Boom Angle (Degrees)	Side Frames Extended (Pounds)	From Boom Pt. to Ground (Feet)
33	80.8	56,790	184	38	80.8	41,260*	214				
35	80.2	52,200	184	40	80.2	40,530*	213				
40	78.6	43,200	183	50	77.4	30,780	211				
50	75.3	31,490	180	60	74.6	23,870	209				
60	71.9	24,560	178	70	71.7	18,910	206				
70	68.6	19,600	174	80	68.8	15,320	202				
80	65.1	16,020	170	90	65.9	12,600	198				
90	61.5	13,310	165	100	62.9	10,470	193				
100	57.8	11,180	159	110	59.7	8,750	188				
110	54.0	9,470	152	120	56.5	7,340	182				
120	49.9	8,070	144	130	53.2	6,160	174				
130	45.6	6,890	135	140	49.7	5,170	166				
140	41.0	5,900	124	150	46.0	4,310	157				
150	35.8	5,060	112	160	42.0	3,570	147				
160	29.9	4,330	96	170	37.8	2,920	135				
170	22.6	3,690	76	180	33.0	2,360	121				
180	11.7	3,150	43	190	27.6	1,860	104				
190' (57.9 m) Boom length				220' (67.1 m) Boom length							
Radius (Feet)	Boom Angle (Degrees)	Side Frames Extended (Pounds)	From Boom Pt. to Ground (Feet)	Radius (Feet)	Boom Angle (Degrees)	Side Frames Extended (Pounds)	From Boom Pt. to Ground (Feet)	Radius (Feet)	Boom Angle (Degrees)	Side Frames Extended (Pounds)	From Boom Pt. to Ground (Feet)
34	81.0	52,440*	194	39	80.9	36,220*	224				
35	80.7	51,980	194	40	80.7	35,920*	223				
40	79.2	42,970	193	50	78.0	30,530	222				
50	76.1	31,260	191	60	75.3	23,640	219				
60	72.9	24,330	188	70	72.6	18,670	216				
70	69.7	19,370	185	80	69.8	15,080	213				
80	66.5	15,790	181	90	67.1	12,350	209				
90	63.2	13,070	176	100	64.2	10,220	204				
100	59.7	10,940	170	110	61.3	8,490	199				
110	56.2	9,230	164	120	58.2	7,090	193				
120	52.4	7,820	157	130	55.1	5,900	187				
130	48.5	6,650	149	140	51.9	4,900	179				
140	44.3	5,660	139	150	48.5	4,050	171				
150	39.8	4,810	128	160	44.9	3,300	162				
160	34.8	4,070	115	170	41.0	2,650	151				
170	29.1	3,430	99	180	36.9	2,090	138				
180	22.0	2,880	78	190	32.3	1,590	124				
190	11.4	2,410	44								
200' (61.0 m) Boom length				230' (70.1 m) Boom length							
Radius (Feet)	Boom Angle (Degrees)	Side Frames Extended (Pounds)	From Boom Pt. to Ground (Feet)	Radius (Feet)	Boom Angle (Degrees)	Side Frames Extended (Pounds)	From Boom Pt. to Ground (Feet)	Radius (Feet)	Boom Angle (Degrees)	Side Frames Extended (Pounds)	From Boom Pt. to Ground (Feet)
36	80.9	46,580*	204	41	80.8	31,600*	233				
40	79.7	42,730	203	50	78.5	27,960*	232				
50	76.8	31,010	201	60	76.0	23,410	230				
60	73.8	24,090	198	70	73.4	18,440	227				
70	70.8	19,130	195	80	70.8	14,840	224				
80	67.7	15,540	191	90	68.1	12,110	220				
90	64.6	12,820	187	100	65.4	9,970	215				
100	61.4	10,690	182	110	62.6	8,250	211				
110	58.0	8,980	176	120	59.8	6,830	205				
120	54.6	7,570	169	130	56.8	5,660	199				
130	51.0	6,390	162	140	53.8	4,660	192				
140	47.2	5,390	153	150	50.6	3,800	184				
150	43.1	4,540	143	160	47.3	3,060	175				
160	38.8	3,800	132	170	43.8	2,410	166				
170	33.9	3,170	118	180	40.1	1,840	154				
180	28.3	2,610	101								
190	21.5	2,120	80								
200	11.1	1,700	45								

* see page 10 „Notes to lifting capacity“

NOTES TO LIFTING CAPACITY

HC 110

Warning

This rating chart is invalid if the crane has been modified or altered by use of other than GENUINE AMERICAN PARTS as such modifications or alterations may affect its capacity or safe operation. See American Crane Corporation Service Bulletin #259.

Ratings in this chart are in POUNDS and do not exceed the percentage of tipping specified for this crane by ANSI B30.5. All ratings require that the crane be standing level on a firm uniformly supporting surface.

Do not lift loads in excess of those shown on this chart. Lifting loads in excess of those shown or operation not in accordance with good operating practice, including limitations shown on page 3499 of Operator's Manual, can cause tipping, structural damage or catastrophic failure.

Asterisk (*) areas on this chart indicate ratings that are limited by strength of material or factors other than stability (tipping).

„RADIUS IN FEET“ is the horizontal distance at ground level from the crane centerline of rotation to a vertical line through the center of gravity of the suspended load.

When using the main boom fall with jib in place, the main fall ratings must be reduced by the jib effective weight shown on the jib rating chart plus twice the weight of all suspended blocks, slings, rope, etc., at the jib fall. See Appendix A.

When using the main boom fall with boom tip extension in place, the main fall ratings must be reduced by the weight of the boom tip extension plus twice the weight of all suspended blocks, slings, rope, etc., at the boom tip extension fall. See Appendix A.

Blocks, slings, buckets and other load carrying devices are considered part of the load. The weight of standard hoisting ropes for the rating at a given radius has been calculated as part of the boom point load and need not be considered in determining net allowable loads. See Appendix A.

This chart was developed exclusively for use with a boom only. Under no circumstances are these ratings to be interpreted for use with a jib.

Ratings shown on this chart make no allowance for such factors as out of plumb loads, wind, poor soil conditions, improper inflation of rubber tires and dynamic effects due to excessive operating speeds. The user (operator) must exercise judgment to make allowance for these conditions. See page 3499 of Operator's Manual for detailed information.

No account is taken of the wind force on the load. The user must consider this effect, which can be substantial for loads with large surface areas. In any wind it is strongly recommended that taglines be used to control the load.

BOOM HOIST LINE – 12 parts of 3/4 inch diameter IPS wire rope with a minimum breaking strength of 51,200 pounds.

PENDANT SUSPENSION LINE – 2 parts of 1-3/8 inch diameter EEIPS wire rope with a minimum breaking strength of 211,000 pounds.

MAIN LOAD LINE – 1.000 inch diameter EIPS wire rope with a minimum breaking strength of 103,400 pounds or 0.875 inch diameter EIPS wire rope with a minimum breaking strength of 79,600 pounds.

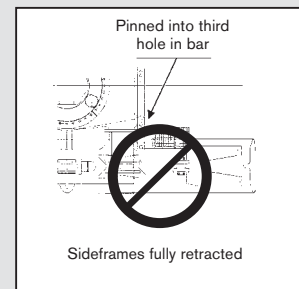
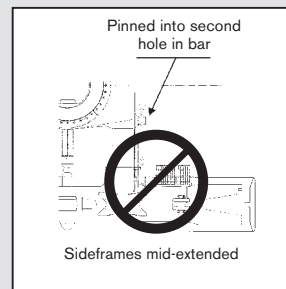
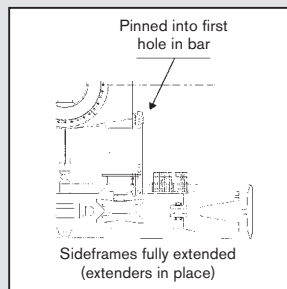

SIDEFAME POSITION DEFINITIONS

These ratings are valid for the sideframe positions as indicated below.

Refer to the HC 110 Operator's Manual for additional information.

59HI OFFSET TIP BOOM MAXIMUM BOOM & JIB SELF-ERECTION DATA				
JIB	OVER-THE-END BLOCKED		OVER-THE-SIDE	
	BOOM LENGTH (FEET)	JIB LENGTH (FEET)	BOOM LENGTH (FEET)	JIB LENGTH (FEET)
9HL	230	0	210	0
	220	0	200	0
	210	40	190	40
	200	70	180	70

LOAD HOISTING INFORMATION - 1.00" diameter EIPS wire rope			
MAXIMUM LIFTING CAPACITY - LBS.	MINIMUM PARTS OF LINE	MAXIMUM HOISTING DISTANCE - FEET	
		MAIN HOIST	AUX HOIST
220,000	8	130	
236,800	7	148	
177,250	6	173	
147,700	5	208	
118,150	4	250	NOT APPLICABLE
88,600	3	346	
59,050	2	520	
29,500	1	1040	

LOAD HOISTING INFORMATION - 7/8" diameter EIPS wire rope			
MAXIMUM LIFTING CAPACITY - LBS.	MINIMUM PARTS OF LINE	MAXIMUM HOISTING DISTANCE - FEET	
		MAIN HOIST	AUX HOIST
181,900	8	78	
158,200	7	89	
136,450	6	104	
118,700	5	125	
90,950	4	156	NOT APPLICABLE
68,200	3	208	
45,450	2	313	
22,700	1	626	

ERECTION

Erection „OVER-THE-END BLOCKED“ is with the boom over the idler end with idler tumbler blocked (See HC 110 Operator's Manual for blocking instructions). Erection „OVER-THE-SIDE“ is with the boom 90° to the sideframes. Blocks, slings and other load carrying devices must be on the ground during erection.

BOOM COMPOSITION CHART - 59HI OFFSET TIP					
BOOM LENGTH (FEET)	BOOM SECTIONS				
	25' 59HI INNER	10' 59H CENTER	20' 59H CENTER	40' 59H CENTER	25' 59HI OUTER
50	1	0	0	0	1
60	1	1	0	0	1
70	1	0	1	0	1
80	1	1	1	0	1
90	1	0	0	1	1
100	1	1	0	1	1
110	1	0	1	1	1
120	1	1	1	1	1
130	1	0	0	2	1
140	1	1	0	2	1
150	1	0	1	2	1
160	1	1	1	2	1
170	1	0	0	3	1
180	1	1	0	3	1
190	1	0	1	3	1
200	1	1	1	3	1
210	1	0	0	4	1
220	1	1	0	4	1
230	1	0	1	4	1



RANGE DIAGRAM

HC 110

59HI Boom, #9HL Jib

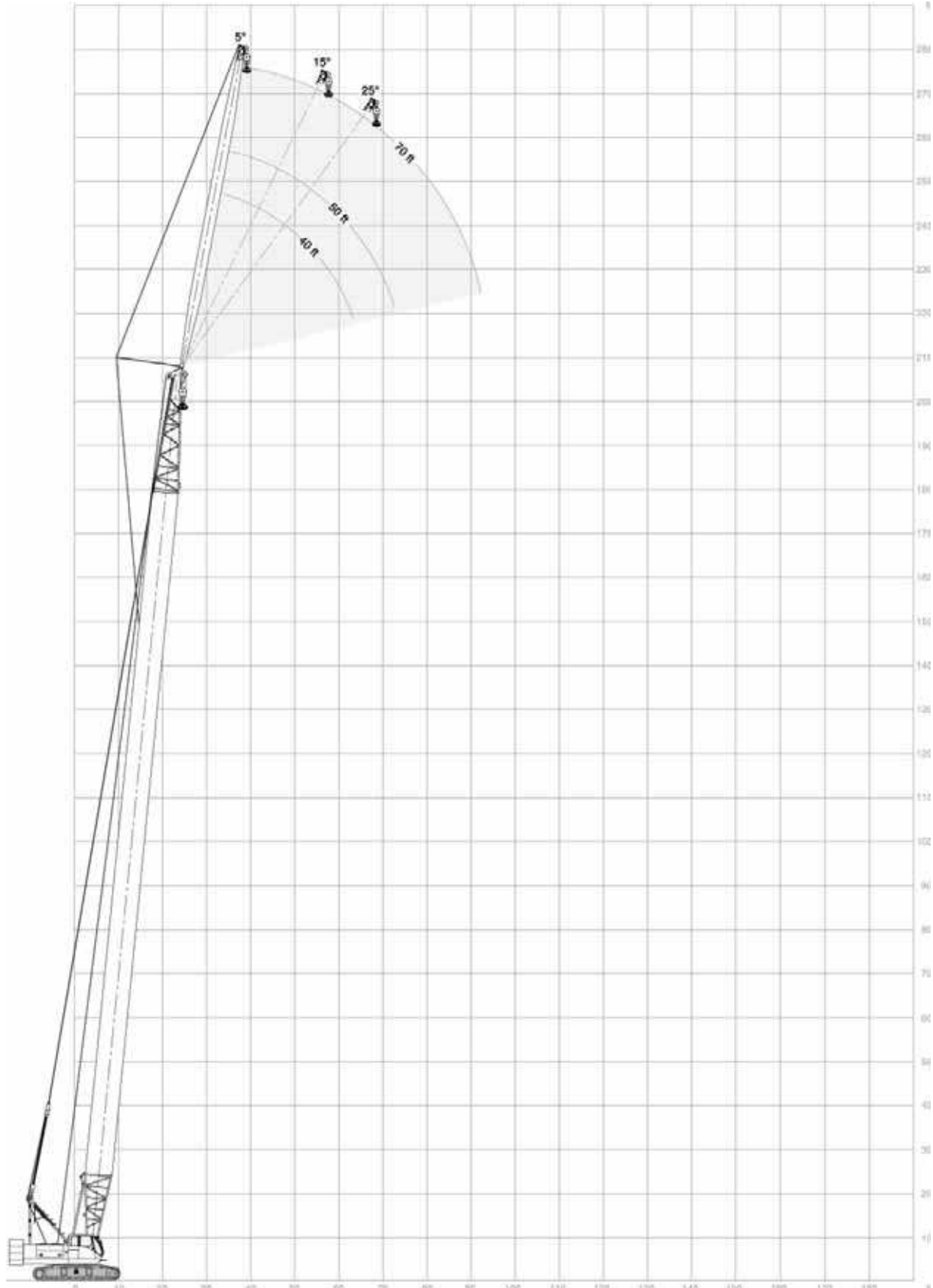

LOAD CHART

HC 110

With 59HI Offset Tip Boom – 4 Sheave Tip, #9HL Jib

52,900 lb + 23,000 lb SC					360°					ANSI B 30.5					
40' (12.2 m) Jib length															
Boom length	Jib Radius (Feet)	5.0 Deg offset Boom Angle	Rating (Pounds)	15.0 Deg offset Boom Angle	Rating (Pounds)	25.0 Deg offset Boom Angle	Rating (Pounds)	Boom length	Jib Radius (Feet)	5.0 Deg offset Boom Angle	Rating (Pounds)	15.0 Deg offset Boom Angle	Rating (Pounds)	25.0 Deg offset Boom Angle	Rating (Pounds)
	30	80.7	22,540*	-	-	-	-		38	80.7	22,470*	-	-	-	-
	35	78.6	22,540*	-	-	-	-		40	80.1	22,470*	-	-	-	-
	40	76.6	22,420*	79.3	21,270*	-	-		50	77.1	22,470*	79.1	21,150*	80.9	20,080*
	50	72.3	21,780*	75.0	20,710*	77.5	19,820*		60	74.0	21,980*	75.9	20,700*	77.8	19,800*
100' (30.5 m)	60	68.0	21,120*	70.7	20,150*	73.1	19,470*		70	70.8	20,490	72.8	20,350*	74.6	19,510*
	70	63.5	20,520*	66.1	19,710*	68.5	18,290*		80	67.6	16,920	69.5	16,920	71.3	16,920
	80	58.9	18,220	61.4	18,220	63.7	16,950*	150' (45.7 m)	90	64.3	14,200	66.2	14,200	67.9	14,200
	90	53.9	15,520	56.5	15,520	58.7	15,520		100	60.9	12,070	62.8	12,080	64.5	12,080
	100	48.7	13,390	51.1	13,390	53.2	13,400	110	57.4	10,360	59.3	10,360	60.9	10,370	
	31	80.9	22,530*	-	-	-	-		120	53.7	8,950	55.6	8,960	57.1	8,960
	35	79.4	22,530*	-	-	-	-		130	49.9	7,770	51.7	7,780	53.2	7,780
	40	77.5	22,530*	80.0	21,320*	-	-		140	45.8	6,780	47.5	6,780	49.0	6,780
	50	73.5	21,900*	76.0	20,820*	78.4	19,920*		150	41.4	5,930	43.1	5,940	44.4	5,940
110' (33.5 m)	60	69.5	21,300*	72.0	20,320*	74.3	19,550*		39	80.9	22,460*	-	-	-	-
	70	65.4	20,770*	67.9	19,840*	70.1	18,820*		40	80.6	22,460*	-	-	-	-
	80	61.1	17,960	63.6	17,970	65.7	17,500*		50	77.7	22,460*	79.6	21,240*	-	-
	90	56.7	15,250	59.1	15,250	61.2	15,260		60	74.8	22,100*	76.7	20,780*	78.4	19,810*
	100	52.0	13,130	54.3	13,130	56.3	13,140	70	71.8	20,230	73.7	20,230	75.4	19,510*	
	110	46.9	11,430	49.2	11,430	51.1	11,430	80	68.8	16,640	70.6	16,650	72.3	16,650	
	33	80.8	22,520*	-	-	-	-	160' (48.8 m)	90	65.7	13,930	67.5	13,930	69.2	13,940
	35	80.1	22,520*	-	-	-	-		100	62.5	11,800	64.3	11,800	65.9	11,800
	40	78.2	22,520*	80.6	21,470*	-	-		110	59.2	10,090	61.0	10,090	62.6	10,090
	50	74.6	22,040*	76.9	20,920*	79.2	19,950*		120	55.8	8,680	57.6	8,680	59.1	8,680
120' (36.6 m)	60	70.9	21,450*	73.2	20,470*	75.4	19,620*		130	52.3	7,500	54.0	7,500	55.5	7,500
	70	67.0	20,970*	69.3	20,010*	71.5	19,310*		140	48.5	6,510	50.2	6,510	51.6	6,510
	80	63.1	17,680	65.4	17,680	67.4	17,680		150	44.5	5,650	46.2	5,650	47.5	5,660
	90	59.0	14,980	61.3	14,980	63.2	14,980		160	40.3	4,910	41.9	4,910	43.1	4,920
	100	54.7	12,850	56.9	12,850	58.8	12,850		41	80.8	22,450*	-	-	-	-
	110	50.2	11,140	52.3	11,140	54.2	11,140		50	78.3	22,450*	80.1	21,260*	-	-
	120	45.3	9,740	47.4	9,740	49.1	9,750	60	75.5	22,170*	77.3	20,850*	79.0	19,890*	
	34	81.0	22,500*	-	-	-	-	170' (51.8 m)	70	72.7	19,990	74.5	20,000	76.1	19,610*
	35	80.6	22,500*	-	-	-	-		80	69.8	16,410	71.6	16,410	73.2	16,410
	40	78.9	22,500*	-	-	-	-		90	66.9	13,690	68.6	13,690	70.2	13,690
	50	75.5	22,190*	77.7	20,980*	79.8	20,010*		100	63.9	11,560	65.6	11,560	67.2	11,570
130' (39.6 m)	60	72.0	21,610*	74.2	20,560*	76.3	19,630*		110	60.8	9,840	62.5	9,840	64.0	9,840
	70	68.5	21,010	70.6	20,130*	72.6	19,330*		120	57.6	8,440	59.3	8,440	60.8	8,440
	80	64.8	17,440	66.9	17,440	68.9	17,450		130	54.3	7,260	56.0	7,260	57.4	7,260
	90	61.0	14,730	63.1	14,730	65.0	14,730		140	50.9	6,260	52.5	6,260	53.9	6,270
	100	57.1	12,610	59.2	12,610	61.0	12,610	150	47.3	5,400	48.9	5,400	50.2	5,410	
	110	52.9	10,900	55.0	10,900	56.8	10,900	160	43.4	4,670	45.0	4,670	46.2	4,670	
	120	48.6	9,490	50.6	9,490	52.3	9,500	170	39.2	4,010	40.8	4,020	41.9	4,020	
	130	43.9	8,320	45.8	8,330	47.4	8,330		42	80.9	22,430*	-	-	-	-
	36	80.8	22,490*	-	-	-	-		180' (54.9 m)	50	78.8	22,430*	80.6	21,360*	-
	40	79.6	22,490*	-	-	-	-	60		76.2	22,300*	77.9	20,920*	79.5	19,910*
	50	76.3	22,330*	78.4	21,060*	80.4	20,060*		70	73.5	19,730	75.2	19,730	76.8	19,610*
	60	73.0	21,760*	75.1	20,620*	77.1	19,710*		80	70.8	16,140	72.5	16,150	74.0	16,150
140' (42.7 m)	70	69.7	20,750	71.8	20,210*	73.7	19,420*		90	68.0	13,420	69.7	13,420	71.2	13,420
	80	66.3	17,170	68.3	17,170	70.2	17,170		100	65.2	11,290	66.8	11,290	68.3	11,290
	90	62.8	14,450	64.8	14,450	66.6	14,460		110	62.3	9,570	63.9	9,580	65.4	9,580
	100	59.1	12,330	61.1	12,330	62.9	12,340		120	59.3	8,160	60.9	8,160	62.3	8,170
	110	55.3	10,620	57.3	10,620	59.0	10,630	130	56.2	6,980	57.8	6,980	59.2	6,990	
	120	51.3	9,210	53.3	9,210	54.9	9,220	140	53.0	5,990	54.6	5,990	55.9	6,000	
	130	47.1	8,040	49.0	8,050	50.5	8,050	150	49.6	5,130	51.2	5,140	52.5	5,140	
	140	42.6	7,050	44.4	7,050	45.8	7,060	160	46.1	4,390	47.6	4,390	48.9	4,390	
								170	42.3	3,740	43.8	3,740	45.0	3,750	
								180	38.3	3,170	39.7	3,170	40.8	3,180	



* see page 17 „Notes to lifting capacity“

LOAD CHART

HC 110

With 59HI Offset Tip Boom – 4 Sheave Tip, #9HL Jib

52,900 lb + 23,000 lb SC 360° ANSI B 30.5

40' (12.2 m) Jib length															
Boom length	Jib Radius (Feet)	5.0 Deg offset Boom Angle	5.0 Deg offset Rating (Pounds)	15.0 Deg offset Boom Angle	15.0 Deg offset Rating (Pounds)	25.0 Deg offset Boom Angle	25.0 Deg offset Rating (Pounds)	Boom length	Jib Radius (Feet)	5.0 Deg offset Boom Angle	5.0 Deg offset Rating (Pounds)	15.0 Deg offset Boom Angle	15.0 Deg offset Rating (Pounds)	25.0 Deg offset Boom Angle	25.0 Deg offset Rating (Pounds)
	44	80.8	21,930*	-	-	-	-		47	80.9	16,340*	-	-	-	-
	50	79.3	21,270*	81.0	19,700*	-	-		50	80.2	16,030*	-	-	-	-
	60	76.8	20,090*	78.4	18,900*	80.0	17,680*		60	77.9	14,900*	79.4	14,170*	80.8	13,290*
	70	74.2	18,990*	75.9	18,040*	77.4	17,090*		70	75.5	13,870*	77.0	13,330*	78.4	12,720*
	80	71.6	15,890	73.3	15,890	74.7	15,890		80	73.1	12,940*	74.6	12,510*	76.0	12,040*
	90	69.0	13,170	70.6	13,180	72.1	13,180		90	70.7	12,040*	72.2	11,700*	73.6	11,330*
190' (57.9 m)	100	66.3	11,030	67.9	11,030	69.3	11,040	210' (64.0 m)	100	68.3	10,530	69.8	10,530	71.1	10,530
	110	63.6	9,320	65.1	9,320	66.5	9,320		110	65.8	8,810	67.3	8,810	68.6	8,810
	120	60.7	7,910	62.3	7,910	63.7	7,910		120	63.3	7,390	64.7	7,390	66.0	7,400
	130	57.8	6,720	59.4	6,730	60.7	6,730		130	60.7	6,210	62.1	6,210	63.4	6,220
	140	54.8	5,720	56.4	5,730	57.7	5,730		140	58.0	5,210	59.4	5,210	60.7	5,210
	150	51.7	4,870	53.2	4,880	54.5	4,880		150	55.3	4,350	56.7	4,350	57.9	4,350
	160	48.5	4,130	50.0	4,130	51.2	4,130		160	52.4	3,610	53.8	3,610	55.0	3,620
	170	45.0	3,480	46.5	3,480	47.6	3,490		170	49.5	2,950	50.8	2,950	51.9	2,960
	180	41.4	2,910	42.8	2,910	43.9	2,910		180	46.4	2,380	47.7	2,390	48.8	2,390
	190	37.4	2,400	38.8	2,410	39.7	2,410		190	43.1	1,870	44.4	1,870	45.4	1,880

	45	81.0	19,010*	-	-	-	-
	50	79.8	18,430*	-	-	-	-
	60	77.3	17,300*	78.9	16,380*	80.4	15,320*
	70	74.9	16,270*	76.5	15,530*	77.9	14,730*
	80	72.4	15,250*	74.0	14,680*	75.4	14,040*
	90	69.9	12,910	71.5	12,910	72.9	12,910
	100	67.4	10,760	68.9	10,770	70.3	10,770
	110	64.7	9,050	66.3	9,050	67.6	9,060
200' (61.0 m)	120	62.1	7,640	63.6	7,640	64.9	7,640
	130	59.3	6,460	60.8	6,460	62.1	6,460
	140	56.5	5,460	58.0	5,460	59.3	5,460
	150	53.6	4,600	55.1	4,600	56.3	4,600
	160	50.6	3,860	52.0	3,860	53.2	3,860
	170	47.4	3,200	48.8	3,200	49.9	3,210
	180	44.0	2,620	45.4	2,630	46.5	2,630
	190	40.4	2,120	41.8	2,120	42.8	2,130
	200	36.6	1,670	37.9	1,670	38.8	1,680

50' (15.2 m) Jib length															
Boom length	Jib Radius (Feet)	5.0 Deg offset Boom Angle	5.0 Deg offset Rating (Pounds)	15.0 Deg offset Boom Angle	15.0 Deg offset Rating (Pounds)	25.0 Deg offset Boom Angle	25.0 Deg offset Rating (Pounds)	Boom length	Jib Radius (Feet)	5.0 Deg offset Boom Angle	5.0 Deg offset Rating (Pounds)	15.0 Deg offset Boom Angle	15.0 Deg offset Rating (Pounds)	25.0 Deg offset Boom Angle	25.0 Deg offset Rating (Pounds)
	37	80.8	20,630*	-	-	-	-		38	81.0	20,560*	-	-	-	-
	40	79.8	20,390*	-	-	-	-		40	80.4	20,410*	-	-	-	-
	50	76.6	19,660*	79.2	17,950*	-	-		50	77.3	19,780*	79.8	17,960*	-	-
	60	73.3	18,970*	75.9	17,500*	78.4	16,210*		60	74.2	19,140*	76.7	17,560*	79.0	16,250*
130' (39.6 m)	70	70.0	18,390*	72.6	16,990*	75.0	15,910*	140' (42.7 m)	70	71.1	18,490*	73.5	17,100*	75.8	15,920*
	80	66.5	17,560	69.1	16,550*	71.5	15,560*		80	67.9	17,290	70.3	16,690*	72.5	15,630*
	90	63.0	14,840	65.6	14,840	67.9	14,570*		90	64.6	14,580	67.0	14,580	69.2	14,580
	100	59.4	12,720	61.9	12,720	64.1	12,730		100	61.2	12,440	63.6	12,450	65.7	12,450
	110	55.6	11,010	58.1	11,010	60.2	11,020		110	57.6	10,730	60.0	10,740	62.1	10,740
	120	51.6	9,600	54.0	9,600	56.1	9,610		120	54.0	9,320	56.3	9,330	58.3	9,330
	130	47.4	8,430	49.8	8,440	51.8	8,440		130	50.1	8,150	52.4	8,160	54.4	8,160
									140	46.0	7,160	48.3	7,160	50.1	7,170

* see page 17 „Notes to lifting capacity“

LOAD CHART

HC 110

With 59HI Offset Tip Boom – 4 Sheave Tip, #9HL Jib

52,900 lb + 23,000 lb SC					360°					ANSI B 30.5						
50' (15.2 m) Jib length																
Boom length	Jib Radius (Feet)	5.0 Deg offset Boom Angle	5.0 Deg offset Rating (Pounds)	15.0 Deg offset Boom Angle	15.0 Deg offset Rating (Pounds)	25.0 Deg offset Boom Angle	25.0 Deg offset Rating (Pounds)	Boom length	Jib Radius (Feet)	5.0 Deg offset Boom Angle	5.0 Deg offset Rating (Pounds)	15.0 Deg offset Boom Angle	15.0 Deg offset Rating (Pounds)	25.0 Deg offset Boom Angle	25.0 Deg offset Rating (Pounds)	
	40	80.9	20,440*	-	-	-	-		46	80.9	19,870*	-	-	-	-	
	50	78.0	19,840*	80.3	17,990*	-	-		50	80.0	19,680*	-	-	-	-	
	60	75.0	19,230*	77.4	17,540*	79.6	16,160*		60	77.6	19,240*	79.5	17,430*	-	-	
	70	72.0	18,650*	74.4	17,150*	76.6	15,930*		70	75.1	18,190*	77.1	16,950*	78.9	15,670*	
150' (45.7 m)	80	69.0	17,030	71.3	16,750*	73.5	15,700*		80	72.6	16,000	74.6	16,010	76.4	15,180*	
	90	65.9	14,310	68.2	14,310	70.3	14,320		90	70.1	13,280	72.1	13,280	73.8	13,280	
	100	62.7	12,190	65.0	12,190	67.1	12,190	190' (57.9 m)	100	67.6	11,150	69.5	11,150	71.2	11,150	
	110	59.4	10,480	61.7	10,480	63.7	10,480			110	64.9	9,430	66.9	9,430	68.6	9,440
	120	56.0	9,070	58.3	9,070	60.2	9,070		120	62.3	8,020	64.2	8,020	65.9	8,020	
	130	52.5	7,890	54.7	7,890	56.6	7,890		130	59.5	6,840	61.4	6,840	63.1	6,840	
	140	48.8	6,890	50.9	6,890	52.7	6,900		140	56.7	5,840	58.6	5,840	60.2	5,840	
	150	44.8	6,040	46.9	6,040	48.6	6,050		150	53.8	4,980	55.6	4,980	57.2	4,980	
	42	80.7	20,290*	-	-	-	-		160	50.8	4,230	52.6	4,230	54.1	4,230	
	50	78.5	19,850*	80.8	17,920*	-	-		170	47.6	3,580	49.4	3,580	50.8	3,590	
	60	75.7	19,320*	78.0	17,590*	80.1	16,150*		180	44.2	3,000	46.0	3,010	47.4	3,010	
	70	72.9	18,740*	75.2	17,180*	77.2	15,930*		190	40.6	2,500	42.3	2,500	43.6	2,510	
	80	70.1	16,770	72.3	16,770	74.3	15,700*									
160' (48.8 m)	90	67.1	14,050	69.3	14,050	71.3	14,050		48	80.8	17,880*	-	-	-	-	
	100	64.1	11,910	66.3	11,910	68.3	11,920		50	80.4	17,660*	-	-	-	-	
	110	61.0	10,200	63.2	10,200	65.1	10,210		60	78.1	16,610*	80.0	15,350*	-	-	
	120	57.9	8,790	60.0	8,790	61.9	8,790		70	75.7	15,590*	77.6	14,620*	79.4	13,570*	
	130	54.6	7,610	56.7	7,610	58.5	7,610		80	73.3	14,650*	75.2	13,910*	77.0	13,060*	
	140	51.1	6,610	53.2	6,610	55.0	6,620		90	70.9	13,010	72.8	13,020	74.5	12,530*	
	150	47.5	5,760	49.5	5,760	51.2	5,770		100	68.5	10,880	70.3	10,880	72.0	10,890	
	160	43.6	5,020	45.6	5,020	47.2	5,020		110	66.0	9,160	67.9	9,160	69.5	9,160	
	43	80.9	20,220*	-	-	-	-		200' (61.0 m)	120	63.5	7,740	65.3	7,740	66.9	7,750
	50	79.1	19,890*	-	-	-	-			130	60.9	6,570	62.7	6,570	64.3	6,580
	60	76.4	19,340*	78.6	17,580*	80.6	16,110*		140	58.2	5,560	60.0	5,560	61.6	5,570	
	70	73.7	18,760*	75.9	17,230*	77.9	15,880*		150	55.5	4,710	57.2	4,710	58.8	4,720	
	80	71.0	16,520	73.1	16,530	75.1	15,660*		160	52.6	3,960	54.4	3,960	55.8	3,970	
	90	68.2	13,800	70.3	13,800	72.3	13,810		170	49.7	3,310	51.4	3,310	52.8	3,320	
170' (51.8 m)	100	65.4	11,670	67.5	11,670	69.4	11,670		180	46.6	2,730	48.3	2,740	49.6	2,740	
	110	62.5	9,950	64.6	9,960	66.4	9,960		190	43.3	2,220	44.9	2,220	46.2	2,230	
	120	59.5	8,540	61.5	8,540	63.4	8,550		200	39.8	1,780	41.4	1,780	42.6	1,780	
	130	56.4	7,360	58.4	7,360	60.2	7,370									
	140	53.2	6,370	55.2	6,370	56.9	6,380									
	150	49.9	5,510	51.8	5,520	53.5	5,520									
	160	46.3	4,770	48.3	4,770	49.8	4,770									
	170	42.6	4,120	44.5	4,120	45.9	4,130									
	45	80.8	20,090*	-	-	-	-									
	50	79.5	19,810*	-	-	-	-									
	60	77.0	19,340*	79.1	17,500*	-	-									
	70	74.4	18,840*	76.5	17,200*	78.4	15,850*									
	80	71.8	16,260	73.9	16,260	75.8	15,670*									
180' (54.9 m)	90	69.2	13,530	71.2	13,540	73.1	13,540									
	100	66.5	11,400	68.5	11,400	70.3	11,410									
	110	63.8	9,690	65.8	9,690	67.5	9,690									
	120	61.0	8,280	62.9	8,280	64.7	8,280									
	130	58.1	7,090	60.0	7,100	61.7	7,100									
	140	55.1	6,090	57.0	6,100	58.6	6,100									
	150	51.9	5,230	53.8	5,240	55.4	5,240									
	160	48.7	4,500	50.6	4,500	52.1	4,500									
	170	45.2	3,840	47.1	3,840	48.5	3,850									
	180	41.6	3,280	43.4	3,280	44.7	3,280									

* see page 17 „Notes to lifting capacity“



LOAD CHART

HC 110

With 59HI Offset Tip Boom – 4 Sheave Tip, #9HL Jib

52,900 lb + 23,000 lb SC					360°					ANSI B 30.5					
60' (18.3 m) Jib length															
Boom length	Jib Radius (Feet)	5.0 Deg offset Boom Angle	Rating (Pounds)	15.0 Deg offset Boom Angle	Rating (Pounds)	25.0 Deg offset Boom Angle	Rating (Pounds)	Boom length	Jib Radius (Feet)	5.0 Deg offset Boom Angle	Rating (Pounds)	15.0 Deg offset Boom Angle	Rating (Pounds)	25.0 Deg offset Boom Angle	Rating (Pounds)
	42	81.0	15,360*	-	-	-	-		47	80.9	15,170*	-	-	-	-
	50	78.8	14,930*	-	-	-	-		50	80.2	15,030*	-	-	-	-
	60	76.0	14,330*	78.7	12,880*	-	-		60	77.8	14,540*	80.1	12,970*	-	-
	70	73.2	13,790*	75.9	12,470*	78.4	11,300*		70	75.3	14,050*	77.7	12,640*	79.9	11,460*
150' (45.7 m)	80	70.3	13,300*	73.0	11,980*	75.5	10,950*		80	72.8	13,640*	75.2	12,320*	77.4	11,130*
	90	67.4	12,800*	70.0	11,530*	72.5	10,620*		90	70.3	13,200*	72.7	11,890*	74.8	10,840*
	100	64.4	12,230*	67.0	11,170*	69.4	10,320*	180' (54.9 m)	100	67.8	11,510	70.1	11,510	72.2	10,560*
	110	61.3	10,570	63.9	10,570	66.2	10,080*		110	65.2	9,790	67.5	9,790	69.5	9,800
	120	58.1	9,170	60.7	9,170	63.0	9,180		120	62.5	8,380	64.8	8,380	66.8	8,390
	130	54.8	7,990	57.4	7,990	59.6	8,000		130	59.7	7,200	62.0	7,200	64.0	7,200
	140	51.4	6,990	53.9	6,990	56.0	7,000		140	56.9	6,200	59.2	6,200	61.1	6,200
	150	47.7	6,130	50.2	6,140	52.3	6,140		150	54.0	5,340	56.2	5,340	58.1	5,340
	44	80.9	15,280*	-	-	-	-		160	51.0	4,590	53.2	4,590	55.0	4,600
	50	79.3	14,940*	-	-	-	-		170	47.8	3,940	49.9	3,940	51.7	3,950
	60	76.6	14,400*	79.2	12,910*	-	-		180	44.4	3,370	46.5	3,370	48.2	3,370
	70	73.9	13,890*	76.5	12,570*	78.9	11,360*								
	80	71.2	13,440*	73.8	12,090*	76.2	11,010*		49	80.8	15,040*	-	-	-	-
	90	68.4	12,970*	71.0	11,690*	73.3	10,660*		50	80.6	14,990*	-	-	-	-
160' (48.8 m)	100	65.6	12,020	68.1	11,280*	70.4	10,400*		60	78.3	14,550*	80.5	12,920*	-	-
	110	62.7	10,30	65.2	10,310	67.5	10,140*		70	75.9	14,080*	78.2	12,620*	80.3	11,440*
	120	59.7	8,890	62.2	8,890	64.4	8,900		80	73.5	13,650*	75.8	12,330*	77.9	11,180*
	130	56.6	7,710	59.1	7,710	61.2	7,720		90	71.1	13,290*	73.4	12,000*	75.5	10,870*
	140	53.4	6,710	55.8	6,710	57.9	6,720	190' (57.9 m)	100	68.7	11,250	70.9	11,250	73.0	10,610*
	150	50.1	5,850	52.5	5,860	54.5	5,860		110	66.2	9,530	68.4	9,530	70.4	9,530
	160	46.5	5,120	48.9	5,120	50.8	5,120		120	63.7	8,110	65.9	8,120	67.9	8,120
									130	61.1	6,940	63.3	6,940	65.2	6,950
	46	80.8	15,200*	-	-	-	-		140	58.4	5,930	60.6	5,930	62.5	5,940
	50	79.8	15,010*	-	-	-	-		150	55.7	5,080	57.8	5,080	59.7	5,090
	60	77.2	14,470*	79.7	12,920*	-	-		160	52.8	4,330	54.9	4,330	56.7	4,340
	70	74.7	13,970*	77.1	12,610*	79.5	11,390*		170	49.9	3,680	51.9	3,680	53.7	3,690
	80	72.1	13,510*	74.5	12,210*	76.8	11,070*		180	46.8	3,100	48.8	3,110	50.5	3,110
	90	69.4	13,120*	71.9	11,790*	74.1	10,760*		190	43.5	2,600	45.5	2,600	47.1	2,610
170' (51.8 m)	100	66.7	11,770	69.2	11,380*	71.4	10,470*		50	80.9	15,000*	-	-	-	-
	110	64.0	10,060	66.4	10,060	68.6	10,060		60	78.7	14,550*	80.9	12,920*	-	-
	120	61.2	8,650	63.5	8,650	65.7	8,650		70	76.5	14,090*	78.7	12,660*	80.7	11,200*
	130	58.3	7,460	60.6	7,470	62.7	7,470		80	74.2	13,710*	76.4	12,380*	78.4	11,200*
	140	55.3	6,460	57.6	6,470	59.6	6,470		90	71.9	13,120	74.1	12,090*	76.1	10,940*
	150	52.2	5,600	54.5	5,610	56.4	5,610		100	69.6	10,980	71.7	10,990	73.7	10,650*
	160	48.9	4,870	51.2	4,870	53.1	4,870	200' (61.0 m)	110	67.2	9,260	69.3	9,260	71.3	9,270
	170	45.5	4,220	47.7	4,220	49.5	4,230		120	64.8	7,850	66.9	7,850	68.8	7,850
									130	62.3	6,660	64.4	6,670	66.3	6,670
									140	59.8	5,660	61.8	5,660	63.7	5,670
									150	57.2	4,800	59.2	4,800	61.0	4,810
									160	54.5	4,060	56.5	4,060	58.3	4,070
									170	51.7	3,400	53.7	3,410	55.4	3,410
									180	48.8	2,830	50.8	2,830	52.5	2,830
									190	45.8	2,320	47.7	2,320	49.3	2,330
									200	42.6	1,860	44.5	1,870	46.0	1,870

* see page 17 „Notes to lifting capacity“

LOAD CHART

HC 110

With 59HI Offset Tip Boom – 4 Sheave Tip, #9HL Jib

52,900 lb + 23,000 lb SC				360°				ANSI B 30.5							
70' (21.3 m) Jib length															
Boom length	Jib Radius (Feet)	5.0 Deg offset Boom Angle	5.0 Deg offset Rating (Pounds)	15.0 Deg offset Boom Angle	15.0 Deg offset Rating (Pounds)	25.0 Deg offset Boom Angle	25.0 Deg offset Rating (Pounds)	Boom length	Jib Radius (Feet)	5.0 Deg offset Boom Angle	5.0 Deg offset Rating (Pounds)	15.0 Deg offset Boom Angle	15.0 Deg offset Rating (Pounds)	25.0 Deg offset Boom Angle	25.0 Deg offset Rating (Pounds)
	50	80.8	11,850*	-	-	-	-		53	80.8	11,750*	-	-	-	-
	60	78.5	11,380*	-	-	-	-		60	79.3	11,490*	-	-	-	-
	70	76.1	10,940*	78.8	9,530*	-	-		70	77.2	11,070*	79.6	9,620*	-	-
	80	73.7	10,510*	76.4	9,140*	78.9	8,120*		80	75.0	10,680*	77.4	9,260*	79.7	8,200*
	90	71.3	10,010*	74.0	8,790*	76.4	7,860*		90	72.8	10,280*	75.2	8,950*	77.5	7,940*
	100	68.9	9,590*	71.5	8,450*	73.9	7,650*		100	70.5	9,820*	73.0	8,630*	75.2	7,740*
180' (54.9 m)	110	66.4	9,160*	69.0	8,180*	71.4	7,430*	200' (61.0 m)	110	68.3	9,340*	70.7	8,340*	72.9	7,540*
	120	63.9	8,450	66.4	7,900*	68.8	7,250*		120	65.9	7,930	68.3	7,930	70.5	7,350*
	130	61.3	7,270	63.8	7,270	66.1	7,060*		130	63.6	6,750	66.0	6,750	68.1	6,760
	140	58.6	6,270	61.1	6,270	63.4	6,280		140	61.2	5,750	63.5	5,750	65.7	5,750
	150	55.9	5,420	58.4	5,420	60.6	5,430		150	58.7	4,880	61.1	4,890	63.1	4,890
	160	53.0	4,670	55.5	4,670	57.6	4,680		160	56.2	4,130	58.5	4,140	60.5	4,140
	170	50.0	4,020	52.5	4,020	54.6	4,030		170	53.6	3,480	55.9	3,490	57.8	3,490
	180	46.9	3,440	49.4	3,450	51.4	3,450		180	50.8	2,910	53.1	2,910	55.0	2,920
									190	48.0	2,400	50.3	2,400	52.1	2,410
									200	45.0	1,940	47.3	1,950	49.0	1,950

	51	80.9	11,820*	-	-	-	-
	60	78.9	11,450*	-	-	-	-
	70	76.7	11,030*	79.2	9,580*	-	-
	80	74.4	10,640*	76.9	9,220*	79.3	8,160*
	90	72.1	10,130*	74.6	8,870*	77.0	7,920*
	100	69.7	9,710*	72.3	8,540*	74.6	7,690*
190' (57.9 m)	110	67.4	9,300*	69.9	8,250*	72.2	7,490*
	120	65.0	8,200	67.4	8,000*	69.7	7,310*
	130	62.5	7,010	64.9	7,020	67.2	7,020
	140	60.0	6,010	62.4	6,020	64.6	6,020
	150	57.4	5,150	59.8	5,150	61.9	5,160
	160	54.7	4,410	57.1	4,410	59.2	4,420
	170	51.9	3,750	54.3	3,760	56.3	3,760
	180	49.0	3,190	51.3	3,190	53.3	3,190
	190	46.0	2,670	48.3	2,670	50.2	2,680

* see page 17 „Notes to lifting capacity“

Warning

This rating chart is invalid if the crane has been modified or altered by use of other than GENUINE AMERICAN PARTS as such modifications or alterations may affect its capacity or safe operation. See American Crane Corporation Service Bulletin #259.

Ratings in this chart are in POUNDS and do not exceed the percentage of tipping specified for this crane by ANSI B30.5. All ratings require that the crane be standing level on a firm uniformly supporting surface.

Do not lift loads in excess of those shown on this chart. Lifting loads in excess of those shown or operation not in accordance with good operating practice, including limitations shown on page 3499 of Operator's Manual, can cause tipping, structural damage or catastrophic failure.

Asterisk (*) areas on this chart indicate ratings that are limited by strength of material or factors other than stability (tipping).

„RADIUS IN FEET“ is the horizontal distance at ground level from the crane centerline of rotation to a vertical line through the center of gravity of the suspended load.

When using the main boom fall with jib in place, the main fall ratings must be reduced by the jib effective weight shown on the jib rating chart plus twice the weight of all suspended blocks, slings, rope, etc., at the jib fall. See Appendix A.

When using the main boom fall with boom tip extension in place, the main fall ratings must be reduced by the weight of the boom tip extension plus twice the weight of all suspended blocks, slings, rope, etc., at the boom tip extension fall. See Appendix A.

Blocks, slings, buckets and other load carrying devices are considered part of the load. The weight of standard hoisting ropes for the rating at a given radius has been calculated as part of the boom point load and need not be considered in determining net allowable loads. See Appendix A.

Ratings shown on this chart make no allowance for such factors as out of plumb loads, wind, poor soil conditions, improper inflation of rubber tires and dynamic effects due to excessive operating speeds. The user (operator) must exercise judgment to make allowance for these conditions. See page 3499 of Operator's Manual for detailed information.

No account is taken of the wind force on the load. This effect, which can be substantial for loads with large surface areas, must be considered by the user. In any wind it is strongly recommended that taglines be used to control the load.

BOOM HOIST LINE – 12 parts of 3/4 inch diameter IPS wire rope with a minimum breaking strength of 51,200 pounds.

PENDANT SUSPENSION LINE – 2 parts of 1-3/8 inch diameter EEIPS wire rope with a minimum breaking strength of 211,000 pounds.

JIB BACKSTAY AND FRONTSTAY LINES – 2 parts of 0.875 inch diameter IPS wire rope with a minimum breaking strength of 69,200 pounds.

JIB WHIP LINE – 7/8 inch diameter EIPS wire rope with a minimum breaking strength of 79,600 pounds.

SIDEFAME POSITION DEFINITIONS

These ratings are valid for the sideframe positions as indicated below. Refer to the HC 110 Operator's Manual for additional information.

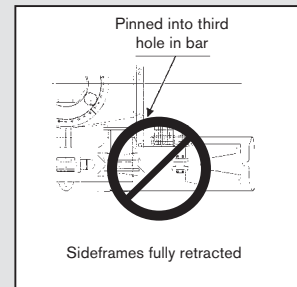
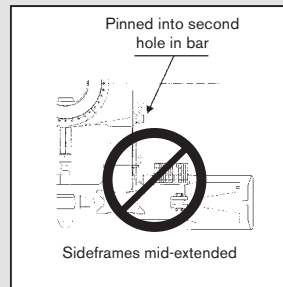
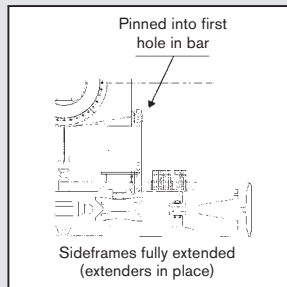

ERECTION

Erection „OVER-THE-END BLOCKED“

is with the boom over the idler end with idler tumblers blocked (See HC 110 Operator's Manual for blocking instructions). Erection „OVER-THE-SIDE“ is with the boom 90° to the sideframes. Blocks, slings and other load carrying devices must be on the ground during erection.

59HI OFFSET TIP BOOM MAXIMUM BOOM & JIB SELF-ERECTION DATA				
JIB	OVER-THE-END BLOCKED		OVER-THE-SIDE	
			SIDEFRAMES FULLY-EXTENDED (WITH EXTENDERS IN PLACE)	
	BOOM LENGTH (FEET)	JIB LENGTH (FEET)	BOOM LENGTH (FEET)	JIB LENGTH (FEET)
SHL	230	0	210	0
	220	0	200	0
	210	40	190	40
	200	70	180	70

BOOM COMPOSITION CHART - 59HI OFFSET TIP					
BOOM LENGTH (FEET)	BOOM SECTIONS				
	25' 59HI INNER	10' 59H CENTER	20' 59H CENTER	40' 59H CENTER	25' 59HI OUTER
100	1	1	0	1	1
110	1	1	1	1	1
120	1	1	1	1	1
130	1	0	0	2	1
140	1	1	0	2	1
150	1	0	1	2	1
160	1	1	1	2	1
170	1	0	0	3	1
180	1	1	0	3	1
190	1	0	1	3	1
200	1	1	1	3	1
210	1	0	0	4	1

LOAD HOISTING INFORMATION - 7/8" diameter EIPS wire rope			
MAXIMUM LIFTING CAPACITY - LBS.	MINIMUM PARTS OF LINE	MAXIMUM HOISTING DISTANCE - FEET	
		MAIN HOIST	AUX HOIST
22,550	1	N/A	626

9HL JIB COMPOSITION CHART								
JIB LENGTH (FEET)	20' INNER	10' CENTER	20' CENTER	20' OUTER	EFF. JIB WEIGHT (POUNDS)	JIB OFFSET "A" IN FEET & INCHES		
						5°	15°	25°
40	1	0	0	1	1,850	4' 9"	9' 9"	14' 8"
50	1	1	0	1	2,350	5' 6"	11' 8"	17' 9"
60	1	0	1	1	2,750	6' 1"	13' 6"	20' 9"
70	1	1	1	1	3,700	6' 8"	15' 6"	24' 0"

Hydraulic Crawler Crane

Maximum lifting capacity

110 tons (100 mt).

Boom systems

59HI Tubular Chord Boom, pin connected – with 4 Sheave Tip

- 230 ft maximum boom length.
- 270 ft maximum boom and jib combination length.
- 25 ft (7.6 m) inner and 25 ft (7.6 m) outer and 10 ft / 20 ft / 40 ft available inserts provide boom compositions in 10 ft (3 m) increments from 50 ft (15.2 m) to 230 ft (70 m).

Robust engine

- Cummins Model QSB 6.7 Turbocharged, after cooler, diesel engine, 4 cycle, 6 cylinders, direct fuel injection, 409 cubic inch displacement, 6.7 liters, 240 BHP@2000 rpm, 105 gallons fuel tank capacity.

Environmental operator's cab

- Designed to provide excellent viewing range and quiet, comfortable operation.
- 37 inch (0.91 m) wide cab has wide curved windows on both top and bottom.
- Easy-to-operate modular and ergonomically designed controls reduce operator fatigue and increase productivity.
- Load Moment Indicator with interactive screen. Operator can select from three display modes: loaded condition diagram, rated lifting curve or rated lifting load table.
- Adjustable operator's seat, radio, air conditioner, overhead window, sun visor, fan, overhead and front wipers and drum rotation indicators are standard.

Heavy duty carbody and crawlers

- Fabricated steel carbody is deep box constructed with square axles for the crawler side frames. Precision machined top supports anti-friction swing circle and multiple pass hydraulic swivel joint.
- Crawlers have high alloy steel tumbler yokes and rigid fabricated structures with sealed rollers.
- 36" (914 mm) crawler shoes.
- Travel mechanism is set within shoe width.
- Side frames extended or retracted by cylinders inside the carbody.
- Two travel speed settings – 0.60 / 0.87 mph (0.96 / 1.4 km/h).
- 30 % (17°) gradeability.

Powerful, high-speed hoist system

- Independent main and auxiliary load hoisting drums. Main drum is grooved for 1 inch (25 mm) diameter rope. Max line speed is 513 fpm (156 m/min), max single line pull is 40,640 lb (18 435 kg). Rated single line pull is 29,500 lb (13 381 kg). Auxiliary drum is grooved for 7/8 inch (22.4 mm) diameter rope. Max line speed is 553 fpm (168 m/min), max single line pull is 37,670 lb (17 086 kg). Rated single line pull is 22,700 lb (10 297 kg). Freefall on main and auxiliary drums.
- Each drum, including optional third, has power up/down and freefall. Load hoists are further controllable in stepless mode.
- Ample work space in front of the drums allows easy access for cable installation and maintenance.
- External contracting brake.
- Internal expanding band clutch.
- 3.0 rpm swing speed.

High capacity, dependable hydraulic system

- Open circuit system has 2 variable displacement piston pumps with system capacity of 183 gpm (692 lpm).
- Hydraulic reservoir with 79 gallons (300 l) capacity and 10 micron filtration.
- Component working range is between -4 and 203° F (-20 and 95° C).

Four piece removable counterweight

- Four piece pin connected counterweight can be assembled or disassembled easily within minutes.
- Hydraulic counterweight removal system is standard and makes the HC 110 one of the most transportable cranes in its class.
- Moves on five trucks with full boom and #9HL jib. At 17 ft, 0.5 inch (5.2 m) wide and 11 ft (3.35 m) high, the basic HC 110 will transport on a standard lowboy trailer.

Options include

- Third drum
- Third drum with free spooling
- Automotive type lights
- Hydraulic power take off
- Jib and jib inserts
- Single sheave extension
- Transportation package
- Single sheave extension
- Tagline winder

TRANSPORT EXAMPLE FOR HC 110

HC 110

With 200 ft 59”H Boom & 70 ft Jib and 3rd Drum

Loads required as follows (weights shown do not include blocking or tie-down material):

LOAD NO. 1 – Step Deck

2 x crawler side frame counterweights (11,500 each)	23,000 lbs
40' boom center section with pendants	2,670 lbs
20 ft jib inner	890 lbs
1 x upper counterweight	4,400 lbs
TOTAL LOAD	30,960 lbs

LOAD NO. 2 – Step Deck

Middle portion of counterweight	12,100 lbs
40' boom center section	2,670 lbs
20 ft jib outer	480 lbs
1 x upper counterweight	4,400 lbs
TOTAL LOAD	19,650 lbs

LOAD NO. 3 – Step Deck

Lower portion of counterweight	32,000 lbs
25 ft boom outer section	4,200 lbs
20' boom center section	1,975 lbs
Main load block	1,500 lbs
Overhaul ball	650 lbs
TOTAL LOAD	40,325 lbs

LOAD NO. 4 – Step Deck

1 x 10' boom center section	1,060 lbs
1 x 40' boom center sections	2,670 lbs
10' jib center section	190 lbs
20' jib center section	385 lbs
TOTAL LOAD	4,305 lbs

LOAD NO. 5

Basic Crane:

- a) Complete upper structure
- b) Carbody and sideframes
- c) Retractable A-frame
- d) Boom inner section and boom stops
- e) Third drum

TOTAL WEIGHT OF BASIC CRANE, etc.)	105,000 lbs
---	--------------------

Effective Date: May 2014.

Product specifications and prices are subject to change without notice or obligation. The photographs and/or drawings in this document are for illustrative purposes only. Refer to the appropriate Operator's Manual for instructions on the proper use of this equipment. Failure to follow the appropriate Operator's Manual when using our equipment or to otherwise act irresponsibly may result in serious injury or death. The only warranty applicable to our equipment is the standard written warranty applicable to the particular product and sale and Terex makes no other warranty, express or implied. Products and services listed may be trademarks, service marks or trade-names of Terex Corporation and/or its subsidiaries in the USA and other countries. All rights are reserved. Terex® is a registered trademark of Terex Corporation in the USA and many other countries.

Copyright Terex Cranes 2014

Terex Cranes, Global Marketing, Dinglerstraße 24, 66482 Zweibrücken, Germany
Tel. +49 (0) 6332 830, Email: info.cranes@terex.com, www.terexcranes.com



www.terexcranes.com

Brochure Reference: TC-DS-I-E-HC110-05/14



WORKS FOR YOU.™

Courtesy of Crane.Market