

IC-400-C

Carry-Deck Industrial Crane

Broderson's long reach 25 US ton capacity carry deck crane, the IC-400 provides heavy duty capacity to take care of all your long reach light and heavy duty lifting needs.

Capacity

50,000 lbs. (22,700 kg)

Sheave Height

98' 6" (30.02 m)

Horizontal Reach

88' (26.83 m)

Height

9' 11" (2.96 m)

Width

8' 6" (2.59 m)



BMC[®] **BRODERSON**[®]
Manufacturing Corp.

www.Broderson.com

IC-400-C

DIMENSIONS

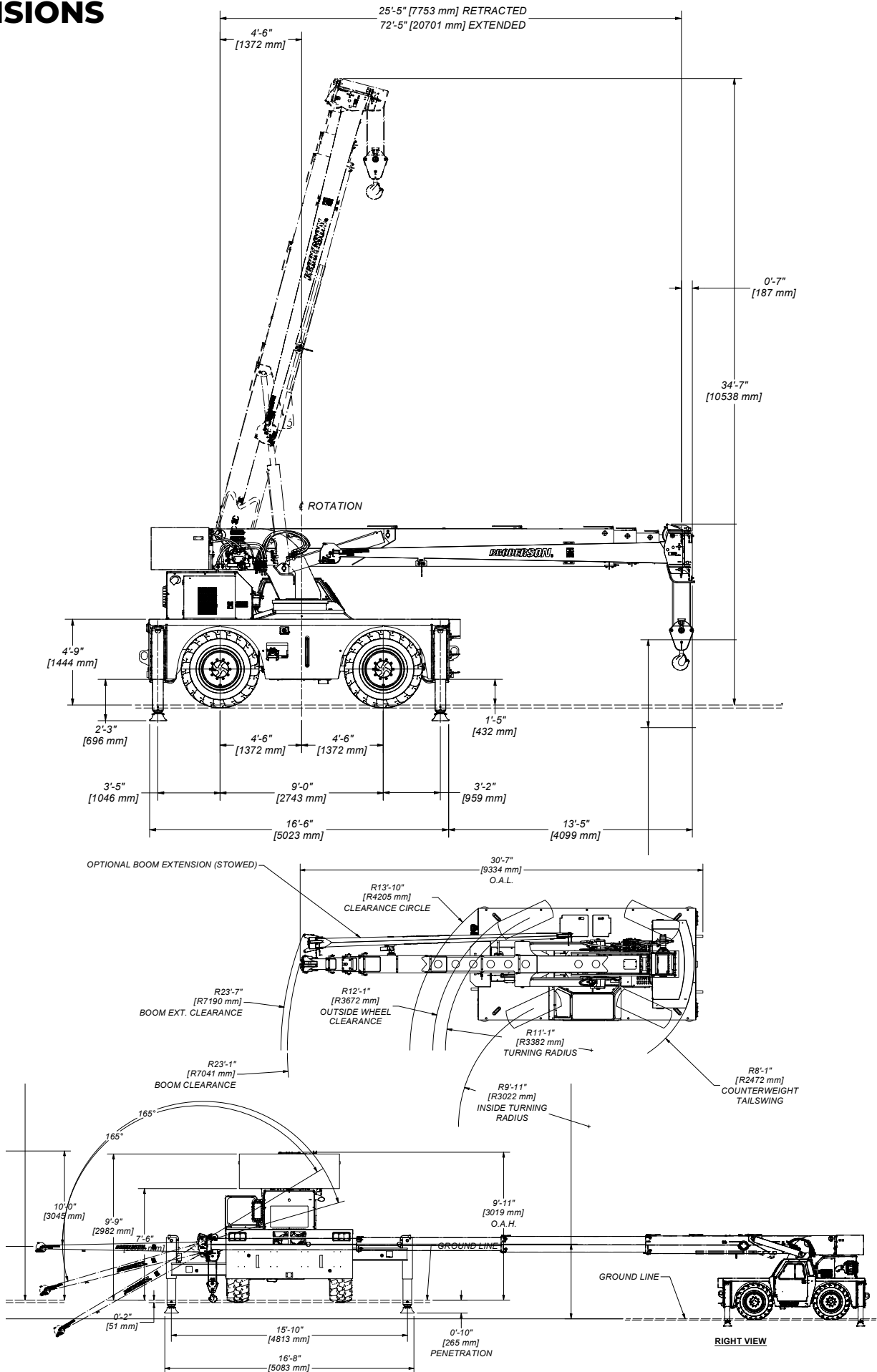

SPECIFICATIONS

GENERAL

| | ROTATION | ELEVATION | EXTENSION |
|-----------------------|--------------------------|-----------|--------------|
| Boom Movement | Continuous | 0° to 75° | 47' (14.33m) |
| Weight Total | 52,300 lbs. (23,725 kg.) | | |
| Front Axle | 26,570 lbs. (12,050 kg.) | | |
| Rear Axle | 25,730 lbs. (11,675 kg.) | | |
| Gradeability | 70% (34°) | | |
| Turning Radius | 11' 1" (3.382 m) | | |

ENGINE

| | |
|---------------------------|--|
| Make | Cummins |
| Model | QSF 3.8 (US EPA Tier 4F/EU Stage V) |
| Type | Turbocharged-Diesel, charge air cooled |
| Cylinder | 4 |
| Displacement | 3.8 L |
| HP at Gov. Speed | 154 HP |
| Fuel Tank Capacity | 80 gal. (302.8 L) |

TRANSMISSION

POWERSHIFT TRANSMISSION with 6-speeds (2 range, 3 speeds/range) forward and reverse. Oil cooler and filter. Operator interface to shift and disconnect front axle for 2-wheel drive operation.

| FORWARD GEAR RATIOS & SPEEDS | | | REVERSE GEAR RATIOS & SPEEDS | | |
|------------------------------|-------|-----------------|------------------------------|-------|-----------------|
| GEAR | RATIO | SPEED (MPH) | GEAR | RATIO | SPEED (MPH) |
| 1st | 9.05 | 1.7 (2.7 km/h) | 1st | 9.05 | 1.7 (2.7 km/h) |
| 2nd | 4.68 | 3.4 (5.5 km/h) | 2nd | 4.68 | 3.4 (5.5 km/h) |
| 3rd | 1.72 | 9.2 (14.8 km/h) | 3rd | 1.72 | 9.2 (14.8 km/h) |
| 4th | 3.73 | 4.2 (6.8 km/h) | 4th | 3.73 | 4.2 (6.8 km/h) |
| 5th | 1.93 | 8.2 (13.2 km/h) | 5th | 1.93 | 8.2 (13.2 km/h) |
| 6th | 0.71 | 22.3 (36 km/h) | 6th | 0.71 | 22.3 (36 km/h) |

AXLES

FRONT
Planetary drive/steer front axle with 19:333 to 1.0 ratio. Differential equipped with 30% "limited slip" feature. Front axle mounted rigidly to frame.

REAR
Planetary drive/steer axle with 19:333 to 1.0 ratio. Rear axle is rigid mounted. Axle has a 30% limited slip-differential.

STEERING

Hydraulic steering unit with a 4 inch (101 mm) bore cylinder attached to each axle. Allows limited steering when engine is not running. Push button operator interface to select between four steer modes: front-wheel, 4-wheel, rear-wheel, or crab steer.

BRAKES

Service: 4-wheel hydraulic internal wet-disc brakes.

Parking: Internal wet disc, spring applied and hydraulically released and integral to the rear axle.

TIRES

Standard:
17.5 x 25, 20-ply rating, mud lug, bi-directional.

CHASSIS

CARGO DECK
Total Deck Area: 74 sq. ft. (6.94 m²) of deck area. 20,000 lbs. (9,100 kg) capacity on deck when load is centered over or between axles. Six deck stakes are provided along edge of deck for 1" (25 mm) pipe stakes. Stakes furnished. Cargo decks have skid resistant coating.

HEADLIGHT AND TAILLIGHT GRILLES
Steel protective grilles for headlights and taillights.

OUTRIGGERS
Four hydraulic out and down outriggers of box beam construction. Independent controls for each outrigger. Outrigger beams have extension sensing and crane has load charts for the positions: out-and-down, mid-and-down, and in-and-down. Outrigger pad dimensions: 11" (27.9 cm). Larger pads available as an option.

ACCESSORY STORAGE BOX
Hinged front deck plate serves as a lockable cover, and box for carrying downhaul weight and other items. Box dimensions 12.25" (.31 m) deep x 13.5" (.34 m) long x 40.25" (1 m) wide.

LIFTING RINGS
Lifting rings at each corner of cargo deck so sling can be attached for lifting crane. Rings hang below surface when not in use.

OPERATOR COMPARTMENT

Provides one-position access to all chassis and crane functions. Includes adjustable operator's seat and seat belt, arm rests, and tilt steering column. Also includes access point to J1939 CAN Bus system.

ALL WEATHER CAB
Consists of rigid mounted canopy section and removable hinged door with safety glass. Rugged canopy structure with laminated glass front and top. Door is equipped with a keyed lock to protect operator's station. Includes defroster fan, dome light, heater with 2-speed fan and 12V electric windshield wiper and windshield washer, 12V power outlet. Emergency exit through rear window.

CLIMATE CONTROL/OPERATOR COMFORT
Integrated heater and air conditioning standard.

ELECTRONIC CONTROLS
Dual, two-axis joysticks provide control of boom functions and hoist. Triggers prevent inadvertent boom motion. Arming command, in conjunction with the seat switch, enables or disables the function of the joysticks. Electronic keypad on dash controls outrigger functions.

ELECTRICAL (12-VOLT SYSTEM)

LIGHTING PACKAGE
One pair of LED headlamps, LED front turn signals, LED taillights with brake, backup and turn signal lights in rear; and one (1) emergency flasher.

OPERATOR DISPLAY
In-dash LED screen show engine data including RPMs, battery voltage, fuel level, hydraulic oil level and temperature, DEF fluid level percent, engine hourmeter, engine fault codes, and control system faults, and hydraulic oil.

Also included are lights for engine warning, engine shutdown, hoist high-speed mode, hydraulic fine control mode and hoist minimum wrap.

BACK-UP ALARM
Provides pulsating sound from 97 dB alarm when transmission is in reverse.

OUTRIGGER ALARM SYSTEM
Two-tone alarm is activated when the OUTRIGGER DOWN, OUTRIGGER BEAMS OUT, and OUTRIGGER BEAMS IN controls are operated.

EMERGENCY STOP SWITCH
A two-position push button switch located on the top left-hand of the dash panel. Designed to stop the engine and shut down the hydraulic system.

HYDRAULIC

TWO AXIAL PISTON PUMPS mounted on and driven by the main transmission, deliver a combine flow of 95 gpm (360L / min) at 4,000 psi (280 bar) and 2,500 RPM engine speed. System protected by relief valves, suction-line strainers, and a 150 gpm, 10-micron return-line filter.

HYDRAULIC RESERVOIR
81 gal (307L) capacity, equipped with a 10-micron breather filter on top and oil level gauge on side.

Four-section, high-strength steel construction, 25' 5" (7.753 m) retracted length 72' 5" (20.7 m) expended length. Hydraulic cylinder with wire rope system that extends and retracts the second, third, and fourth stages proportionally. The telescope cylinder and the boom elevation cylinders are equipped with cylinder mounted holding valves. Boom angle indicator is provided on left side of boom.

BOOM ROTATION
Heavy-duty ball bearing rotation gear with external teeth. Rotation is powered by hydraulic motor and worm gear drive. Rotation gear box may be adjusted as wear occurs to minimize backlash.

BOOM HOIST
Two-speed hoist. A 12 VDC solenoid at motor for speed selection, this is a planetary gear hoist with spring set, hydraulically released brake and load holding valve. The maximum bare drum Line Pull is 17,262 lbs. (7,830 kg), and maximum line speed is 329 ft/min (100.3 m/min) (6th layer). Main hoist rope: 425 ft. (130 m) long, compact 35 rotation resistant, IWRC RRL lay, grade 2160 wire rope with a minimum breaking strength of 56,400 lbs (251 kN). Weight per foot: 0.88 lbs (11.31 kg per/m). Note: rope weight is not included in load calculations. Downhaul weight and hook included — standard.

ANTI-TWO-BLOCK DEVICE
Prevents damage to hoist rope and/or crane components from pulling load hook against tip.

BRODERSON RATED CAPACITY LIMITER
Warns operator of impending overload with audible and visual signals, stopping boom functions that will cause overloads.

FOUR-PART-LINE SHEAVE BLOCK
Double-sheave block for 4-part-line requirements. Downhaul weight and hook included as standard.



Main Features

RATED CAPACITY LIMITER
Broderson RCL Standard

CAPACITY ON OUTRIGGERS
50,000 lbs. (22,700 kg)

PICK AND CARRY CAPACITY
25,000 lbs. (11,340 kg)

HEIGHT
11'3" (3.43 m)

WIDTH
8' 6" (2.59 m)

BOOM ROTATION
360°

SHEAVE HEIGHT
up to 99' (30.18 m)

HORIZONTAL REACH
up to 90' (27.03 m)

FOUR-WHEEL STEER
Standard

FOUR-WHEEL DRIVE
Standard

POWERSHIFT TRANSMISSION
Standard

TIGHT TURNING RADIUS

**FULLY ELECTRONIC CONTROLS
FOR SMOOTH, PRECISE
OPERATIONS**

**INDEPENDENT OUTRIGGER
CONTROLS**
3 Outrigger widths

Additional Features

TIRE OPTIONS
Spare tire and wheel

CHASSIS OPTIONS

Auxiliary Winch

Planetary gear winch mounted beneath chassis frame, with push-button control in operator's console.

Pintle Hook

T-60-AOL Holland pintle hook mounted on front outrigger frame member or rear frame member.

OPERATOR COMPARTMENT

Floor Mat

Vinyl mat with foam backing.

Sun Visor

Adjustable sun visor for reducing glare mounted in roof of cab.

ELECTRICAL OPTIONS

Strobe Lights

Yellow LED strobe light mounted on each side of turret weight box

Camera System

Camera video system (consisting of up to 4 cameras) to assist operator with hard-to-see viewpoints

Or: Rear camera system: 1 back up camera. Display in cabin.

Boom Work Lights

One LED worklight mounted to boom to light boom tip, and one work light mounted to turret to light ground under boom tip.

RCL Light Bar

3 color light bar for external indication of load status

Diagnostic Modem

For crane control system to diagnose faults, allow remote support, and provide software updates.

BOOM ATTACHMENTS:

Boom Extension

20 ft. (6.1 m) offset. Boom stowable. Boom extension is offsettable to 3 different positions; 0 degree (in-line), 15 degree and 30 degree offset. Maximum Sheave height is 99'3", and maximum reach is 90'.

CONSULT THE IC-400-C ENGINEERING SPEC FOR ADDITIONAL INFORMATION.

Broderson Cranes are manufactured to ISO 9001 certified standards and have a market leading reputation for quality and reliability. Broderson Cranes are engineered for operating efficiency and are easy to operate and maintain.

An extensive network of full-service dealers offer parts and service support by factory-trained technicians.

For additional options or special equipment not listed, please consult your dealer salesperson or contact **Broderson Manufacturing Corp.**

BRODERSON[®]
Manufacturing Corp.

14741 West 106th Street
Lenexa, KS 66215 USA

(913) 888-0606
www.Broderson.com

Dimensions and values shown are for reference purposes only. Specifications subject to change.



BMC_ptsbltJt_0424

LN324C