

IC-250-E **Industrial Crane**

The IC-250 has the versatility to perform facility maintenance, re-fits, upgrades and expansion projects. This quality crane will keep you productive every step of the way.

Capacity

36,000 lbs. (16,330 kg)

Sheave Height

79' 6" (24.23 m)
(with boom extension)

Horizontal Reach

70' 1" (21.4 m)
(with boom extension)

Height

7' 11" (2.41 m)

Width

7' 10" (2.39 m)



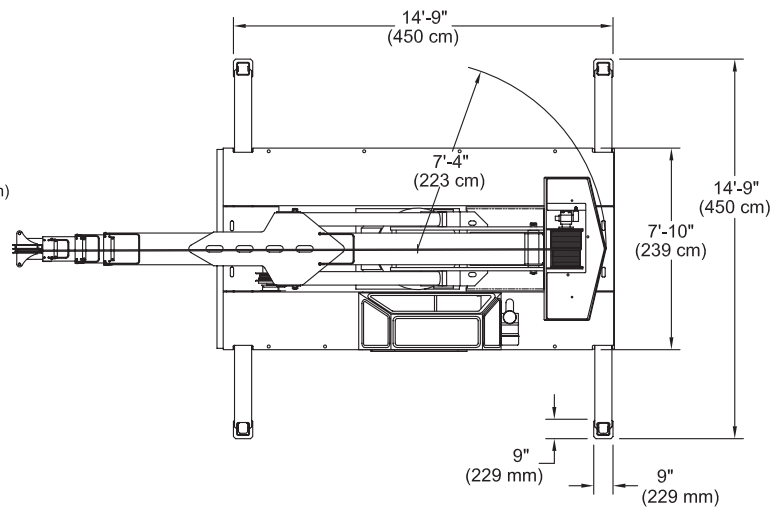
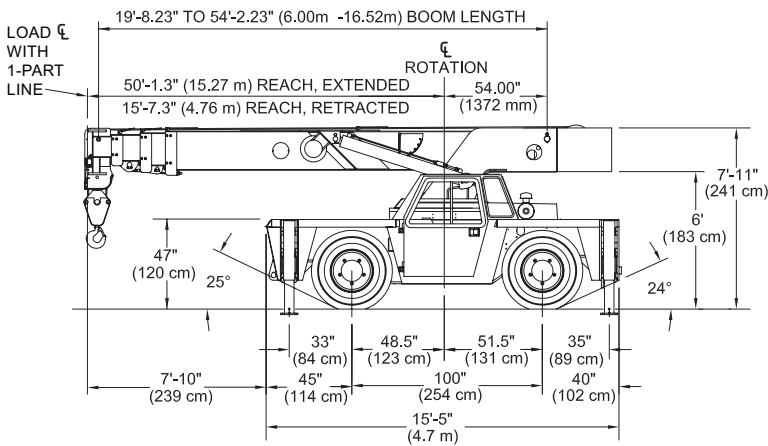
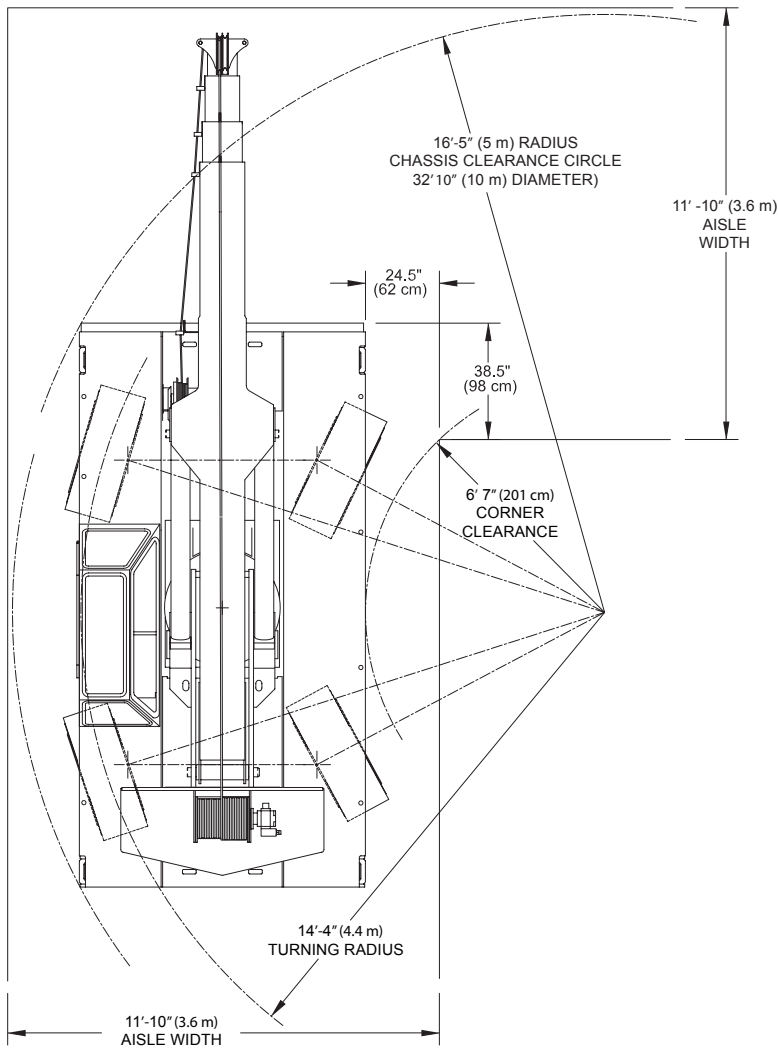

IC-250-E

GENERAL SPECIFICATIONS



GENERAL

	ROTATION	ELEVATION	EXTENSION
Boom Movement	Continuous	0' to 75'	34'6" (10.52m)
Boom Speeds	1.4 RPM	22 sec.	41 sec.

Weight Total	37,700 lbs. (17,100 kg.)		
Front Axle	17,100 lbs. (7,800 kg.)		
Rear Axle	20,600 lbs. (9,300 kg.)		
Gradeability	64% (33')		
Turning Radius	14' 4" (4.37m)		

ENGINE

Make	Cummins	GM
Model	QSF3.8 T4F / QSB3.3 T4i	5.7L V8 (T2)
Type	Turbo-Diesel	LPG
Cylinder	4 / 4	8
Displacement	3.8L / 3.3L	5.7L
HP @ Gov. Speed	120HP (89kW) / 99HP (75kW)	135HP (101kW)
Fuel Tank Capacity	30 gal. (113L)	Dual 43lb. (19.5 kW)

TRANSMISSION

POWERSHIFT TRANSMISSION with 4-speeds forward & reverse. Provides power shifts at any engine speed in any gear. All shifting is done with a single lever electrical control mounted on the steering column. Multiple-disc clutch packs operated by solenoid valves provide reverse, neutral, forward and speed selection. Equipped with torque converter and transmission oil cooler.

GEAR RATIOS:

1st	5.72:1
2nd	3.23:1
3rd	1.77:1
4th	1.00:1

FRONT

Planetary drive/steer front axle with 16:42 to 1.0 ratio. Differential equipped with "limited slip" feature. Front axle mounted rigidly to frame.

TRANS. GEAR	SPEED	DRAWBAR PULL*
1st	3 MPH	18,100 lbs. (8,200 kg)
2nd	5 MPH	10,600 lbs. (4,800 kg)
3rd	10 MPH	6,000 lbs. (2,700 kg)
4th	18 MPH	3,200 lbs. (1,450 kg)

*Drawbar pull is calculated for QSB 3.3L Tier 4i Diesel engine.

REAR

Standard (2-Wheel Drive):

Steering axle with 1-1/2 degree oscillation in either direction.

Optional (4-Wheel Drive):

Planetary drive/steer axle with 24.98 to 1.0 ratio. Differential is not "limited slip" in rear axle. 1-1/2 degree oscillation in either direction. Axle ratio compatible with 4-wheel drive transmission rear output ratio to match front axle speed.

AXLES

Hydraulic steering unit with two cylinders attached to each axle. Allows limited steering when engine is not running. A switch on the control panel is used to select rear-wheel steering or four-wheel (round) steering or crab steering.

STEERING

Service: Split-system, 4-wheel hydraulic-boosted multiple plate wet disc brakes.

Parking: Hand lever actuated disc-type parking brake on transmission.

BRAKES

Standard:

385/65 D22.5, 16-ply high traction on/off road tread.

TIRES

CHASSIS

CARGO DECK

80 Square feet (7.4 m) of deck area. 17,000 lbs. (7,700 kg) capacity on deck when load is centered over or between axles.

OUTRIGGERS

Four hydraulic out & down outriggers of box beam construction with direct-connected holding valves. Independent controls for each outrigger. **Outrigger pad dimension 9" (23 cm) x 9" (23 cm)**

ACCESSORY STORAGE BOX

Storage box is 14" (35 cm) deep x 12½" (32 cm) long x 36 ½" (93 cm) wide, located in front cargo deck.

LIFTING RINGS

Lifting rings at each corner of cargo deck so sling can be attached for lifting crane.

OPERATOR COMPARTMENT

Provides one-position access to all chassis & crane functions. Includes adjustable operator's seat, retracting seat belts, fire extinguisher & bubble level.

ELECTRICAL (12-VOLT SYSTEM)

LIGHTING PACKAGE

Consists of two 12V-lamps, with high and low beams for driving; tail, brake and turn signal lights and backup lights in rear; front turn signals and emergency flasher switch at operator's station.

INSTRUMENT PACKAGE

Fuel gauge and hourmeter which records hours only during actual engine operation. Also included are warning lights for low oil and transmission pressure, check engine, high coolant and transmission temperature, turn signals, high beams, hazard lights, parking brake and four-wheel drive.

BACK-UP ALARM

Provides pulsating sound from 102 dB alarm when transmission is in reverse. Conforms to SAE J994B.

OUTRIGGER ALARM SYSTEM

Two-tone alarm is activated when "outrigger down" or "outrigger out" controls are operated.

HYDRAULIC

TANDEM PUMP direct-driven by engine, delivers 30 GPM (113L/min) at rated RPM. 54-gallon capacity.

BOOM ASSEMBLY

FOUR-SECTION BOOM ASSEMBLY

equipped with bearing pads, double acting hydraulic cylinder & chain system telescopes booms proportionally. Telescope & boom elevation cylinders equipped with cylinder-mounted holding valves. Boom angle indicator on each side of boom.

BOOM ROTATION

Heavy-duty ball bearing rotation gear with external teeth. Rotation is powered by hydraulic motor & worm gear drive.

BOOM HOIST

Turret-mounted planetary gear hoist, is hydraulically powered to provide a bare-drum line pull of 12,000 lbs (5440 kg) and a speed of 100 fpm (30 m/min), includes 320 feet (97 m) of 9/16 inch (14 mm) wire rope, 170 pound (77 kg) downhaul weight, swivel hook, sheave block for 4-part line.

ANTI-TWO-BLOCK DEVICE

Prevents damage to hoist rope and/or crane components from pulling load hook against tip.

RATED CAPACITY LIMITER

Warns operator of impending overload with audible & visual signals. Prevents overload by stopping boom functions that cause overloads.

CONSULT THE IC-250-E ENGINEERING SPEC FOR ADDITIONAL INFORMATION.

Main Features

RATED CAPACITY LIMITER
Standard

CAPACITY ON OUTRIGGERS
36,000 lbs. (16,330 kg)

PICK AND CARRY CAPACITY
up to 18,500 lbs. (8,400 kg)

HEIGHT
7' 11" (2.41 m)

WIDTH
7' 10" (2.39 m)

BOOM ROTATION
360°

SHEAVE HEIGHT
up to 79' 6" (24.23 m)

HORIZONTAL REACH
up to 70' 1" (20.4 m)

FOUR-WHEEL STEER
Standard

FOUR-WHEEL DRIVE
Optional

POWERSHIFT TRANSMISSION
Standard

**FULLY HYDRAULIC CONTROLS FOR
SMOOTH, PRECISE OPERATIONS**

**INDEPENDENT OUTRIGGER
CONTROLS**

**DIESEL OR LPG FUELED ENGINES
AVAILABLE**

ENGINE

Spark Arrester Muffler

Installed in addition to standard muffler.
(LPG only.)

Engine Heater

Engine coolant heater installed to circulate warm water through engine, plugs into 120 volt AC.

AXLE & STEERING

4-Wheel Steer & 2-Wheel Drive
4-Wheel Steer & 4-Wheel Drive

TIRE

Non Marking Pneumatic Tires
Foam Filling of Tires
Spare Tire & Wheel

CHASSIS

Auxiliary Winch

Mounted on front outrigger bumper, hydraulically driven with control in operator's console.

Pintle Hook

Rear and Front

Rearview Mirrors

One mounted on right-hand deck stake and one mounted on left-hand deck stake.

Outrigger Shoes

Steel outrigger shoes, 18" (46 cm) x 18" (46 cm) octagonal shape with storage posts on rear bumper.

OPERATOR COMPARTMENT

Operator Guard

Tubular steel weldment with heavy expanded steel mesh top section.

All Weather Cab

Rigid-mounted canopy section and removable hinged door. Includes heater, electric windshield wiper, one sliding glass window in the door & one in the right side of canopy. Defroster fan & dome light included.

Options

Cab Heater Only

Heater with two-speed fan for units without All Weather Cab.

Windshield Washer

Includes reservoir, pump and nozzle.

Floor Mat

Vinyl mat with foam backing.

Operator Suspension Seat

Small suspension built in to provide additional operator comfort. Deluxe seat upholstery springs provide additional operator comfort.

Noise Reduction Kit

Includes floor mat, control valve cover and side panels of foam backed vinyl for noise reduction.

Air Conditioning

Air Conditioner w/134 coolant.

ELECTRICAL

Strobe Lights

Yellow strobe light mounted on each side of turret weight box.

Boom Work Lights

One worklight mounted to boom to light boom tip, and one work light mounted to turret to light ground under boom tip.

Work Lights - Rear

Two work lights recessed in rear bumper

RCL Light Bar

3 color light bar for external indication of load status

BOOM ATTACHMENTS

Boom Extension

20 ft. (6.1 m) Offset. Boom stowable. Boom extension is offsettable to 3 different positions; 0 degree (in line), 15 degree and 30 degree offset.

Sheave Block

Two-Part Line

Searcher Hook

Nose Mount 5,000 lb (2,270 kg)

Broderson Cranes are manufactured to ISO 9001:2015 certified standards and have a market leading reputation for quality and reliability. Broderson Cranes are engineered for operating efficiency and are easy to operate and maintain.

An extensive network of full-service dealers offer parts and service support by factory-trained technicians.

For additional options or special equipment not listed, please consult your dealer salesperson or contact Broderson Manufacturing Corp.

BRODERSON[®]
Manufacturing Corp.
14741 West 106th Street
Lenexa, KS 66215 USA

(913) 888-0606
www.BMCCranes.com

Dimensions and values shown
are for reference purposes
only. Specifications subject
to change.

